

STACK ABL

PLATFORM GUIDE

2026



Photo © Patrick Biller

Table of Contents

MISSION	<u>03</u>	TECH SPECS	<u>32</u>	CARE AND WARRANTY	<u>47</u>
Design Statement	<u>04</u>	Lighting Performance Profile	<u>33</u>	Care and Maintenance	<u>48</u>
Materials	<u>06</u>	Lighting Acoustic Data	<u>34</u>	Warranty Coverage	<u>49</u>
				Sales Terms & Conditions	<u>50</u>
CONFIGURABLE PRODUCTS	<u>08</u>	ENVIRONMENTAL CERTIFICATIONS	<u>35</u>	DESIGN COLLABORATIONS	<u>51</u>
Lamps	<u>09</u>	Embedded Material Certifications	<u>36</u>	2021 Maison Gerard - Furniture	<u>53</u>
Single Pendants	<u>12</u>	Product Certifications	<u>38</u>	2022 Maison Gerard - Lighting	<u>60</u>
Cluster Pendants	<u>16</u>	Certification Support	<u>39</u>	2023 Jeff Forrest	<u>65</u>
Sconces	<u>20</u>	Red List Compliance	<u>40</u>	2023 Mindy Solomon	<u>67</u>
Canopy Types	<u>22</u>			2024 Benoist F. Drut	<u>70</u>
		CONSTRUCTION AND INSTALLATION	<u>41</u>	2025 Rockwell Group	<u>73</u>
CONFIGURATION	<u>24</u>	Pendant Construction	<u>42</u>		
Product Builder	<u>25</u>	Installation Components	<u>43</u>	RECOGNITIONS AND ENGAGEMENT	<u>76</u>
Color Moods	<u>26</u>	Pendant Mounting	<u>44</u>	Awards, Exhibits, Select Press	<u>80</u>
Patterning	<u>28</u>	Canopy Assembly	<u>45</u>	Lectures and Panels	<u>81</u>
Color Customization	<u>29</u>	Pendant Wiring	<u>46</u>		

STACK ABL

MISSION

Design Statement
Materials



Photo © Patrick Biller

Stackabl turns waste into wonders by transforming regional textile offcuts and other industrial remnants into design-led lighting and furniture. Its proprietary system uses minimal processing to aggregate multiple waste streams and convert them into modular, customizable products engineered for disassembly and material recovery. Layered forms unite biodegradable wool and cork with PET, aluminum, and stone into a singular design language.

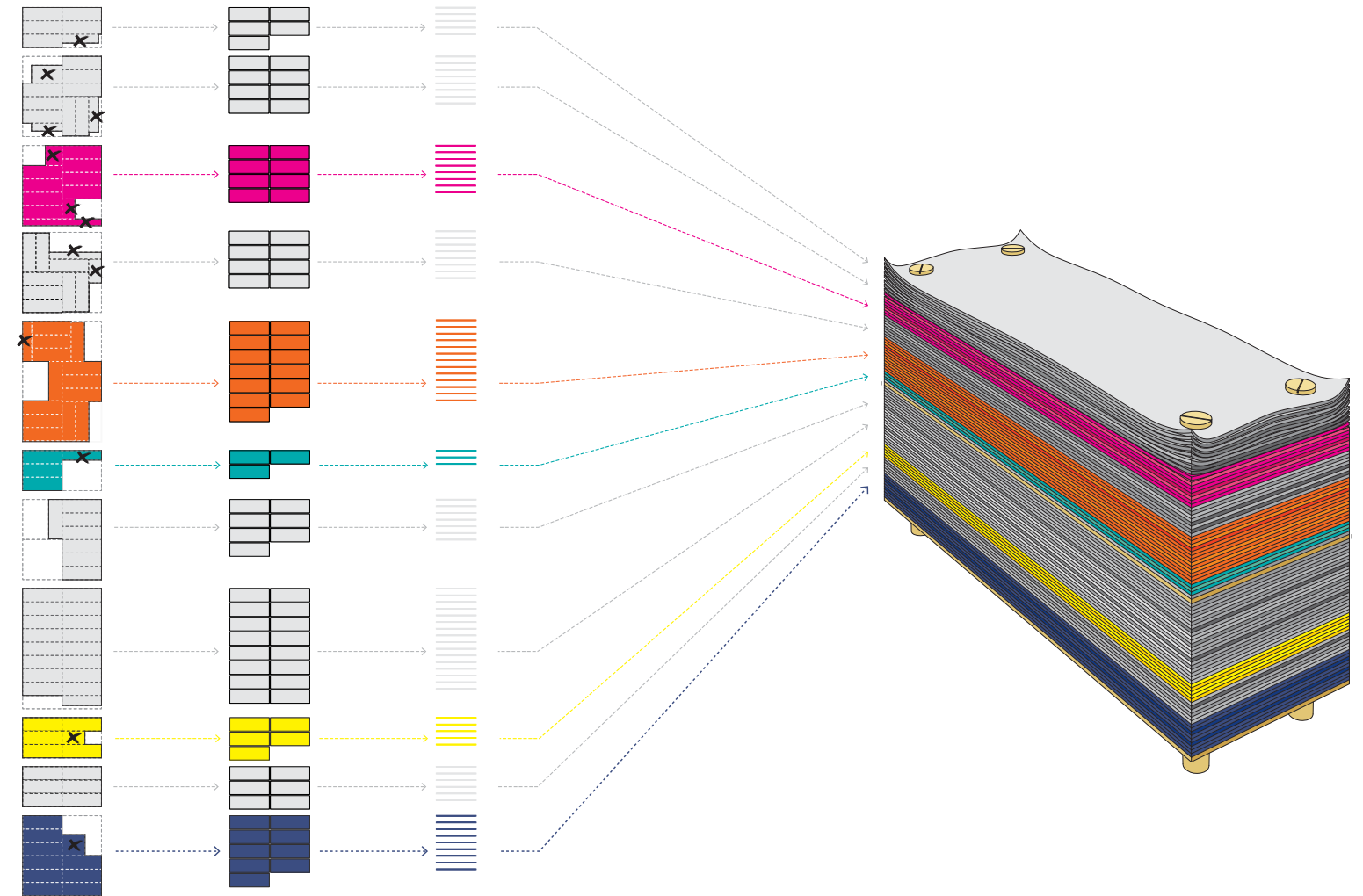

Platform Concept Diagram

© Stackabl

The resulting pieces are sculptural, durable, and acoustically effective for hospitality, workplace, and residential settings. Real-time specification through Stackabl's configurator and supply-chain-driven colorways keep production agile. With a commitment to divert 500 tons of textile waste by 2029, the studio offers a new model for scalable, regionally rooted circular production.



Left: Miller Knoll Textile Remnants

Right: Form 58 Collection
585 Pendant
Photo © Alex Willms

Stackabl partners with **FilzFelt** (a MillerKnoll company) and **Sutherland Felt** to source the Merino wool and PET offcuts that form the core of its furniture and lighting. The studio also works with **Eurasia** for post-industrial stone and **Amorim** for post-consumer cork wine stoppers, which become the bases that anchor its products.

CURRENT OPTIONS

Because Stackabl works exclusively with high-quality remnants from its manufacturing partners, its selection of felt, PET, and stone reflects available inventory and evolves over time. New colors and finishes are introduced as unique remnants become available.

MATERIAL RELEASE 02

Natural Felted Merino Wool - Premium Remnant (Base) Colors (mix of 3mm and 5mm)



60% Recycled Polyethylene Terephthalate (PET) Colors (9mm)



Natural Stone

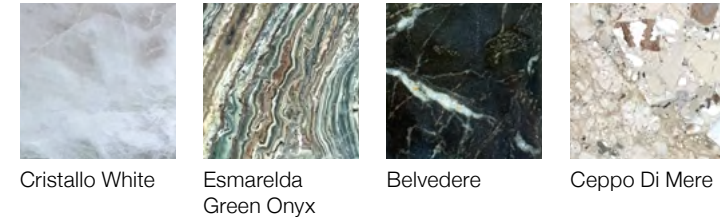

Cork

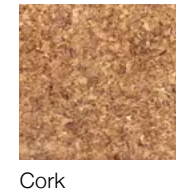

STANDARD FINISHES

Pendant Cables



USBC Cable

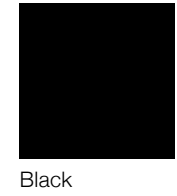

Metal Components

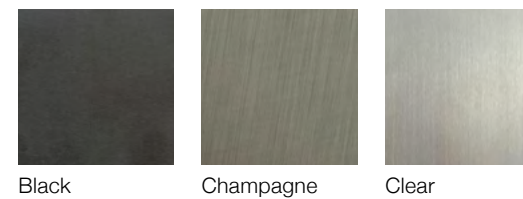

STACK ABL

CONFIGURABLE PRODUCTS

Lamps

Single Pendants

Cluster Pendants

Sconces

Canopy Types



Form 58 Collection

Pendant Cluster

© Stackabl

Lamps - Tilt & Shift

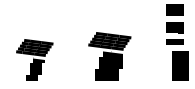
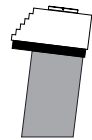
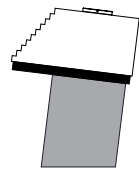

TABLE LAMPS



Tilt 06
9" H x 5 1/4" W x 5 1/4" D



Tilt 11
10 3/4" H x 8 1/2" W x 8 3/4" D

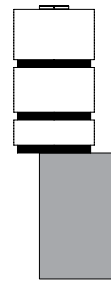

Shift 20
19 1/4" H x 5 1/2" W x 6 3/4" D

■ Non-customizable area



Tilt 11

Photo © Ed Reeve for Rockwell Group

Lamps - Tilt & Shift

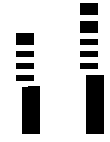

FLOOR LAMPS

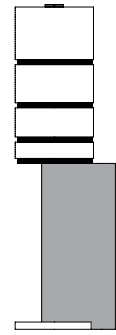

Shift 36

35 1/4" H x 8 1/4" W x 10 7/8" D
Aluminum base / Stone base

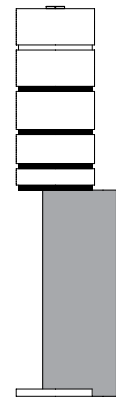

Shift 46

45 1/4" H x 8 1/4" W x 10 7/8" D
Aluminum base / Stone base

■ Non-customizable area

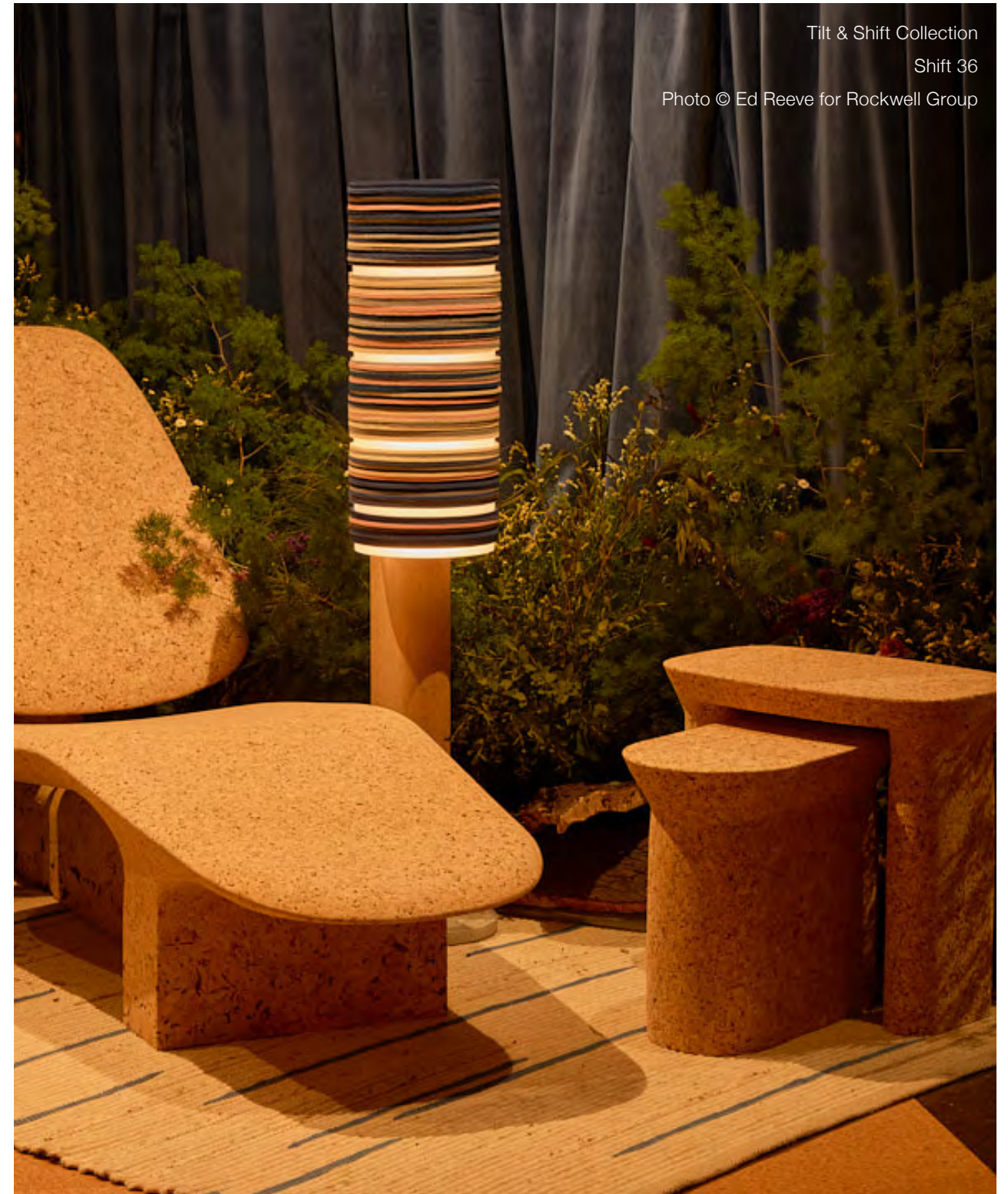

Tilt & Shift Collection
Shift 36
Photo © Ed Reeve for Rockwell Group

Lamps - Column

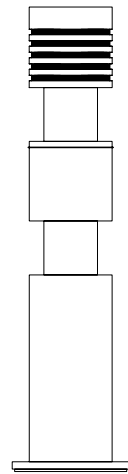
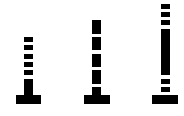

Column 48
48" H x 12" base

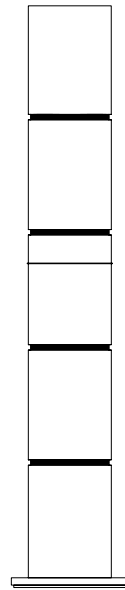

Column 60
60" H x 12" base

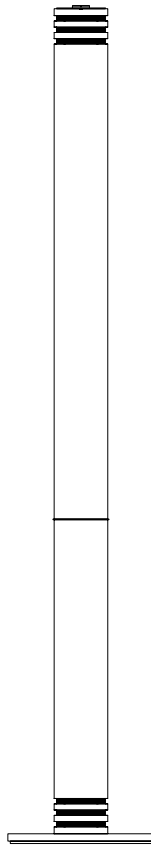

Column 85
85" H x 15" base

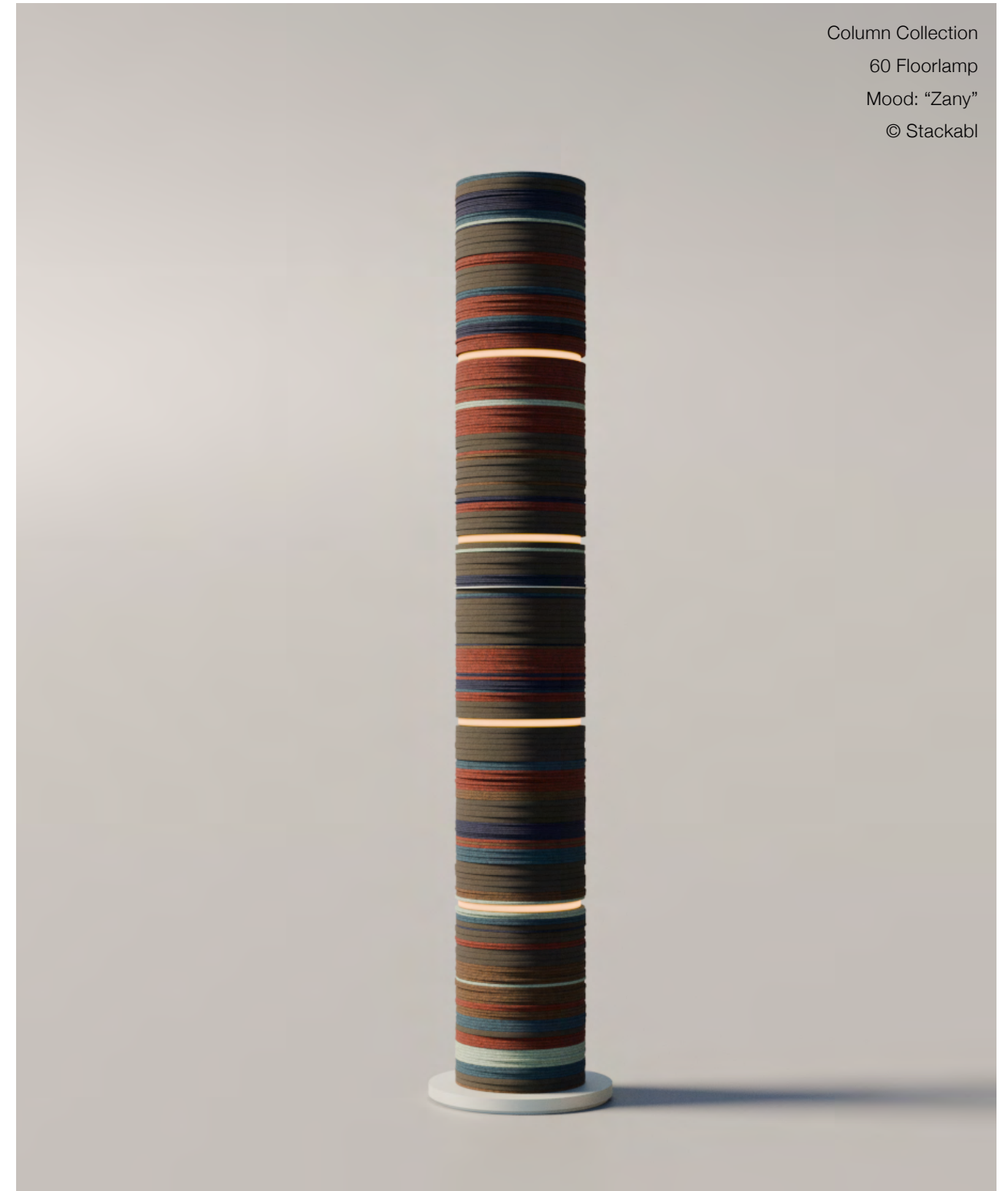

Column Collection
60 Floorlamp
Mood: "Zany"
© Stackabl

Single Pendant - Form 5 and 8 Horizontal



Pendant 5

- 24" L
- 36" L
- 48" L
- 60" L

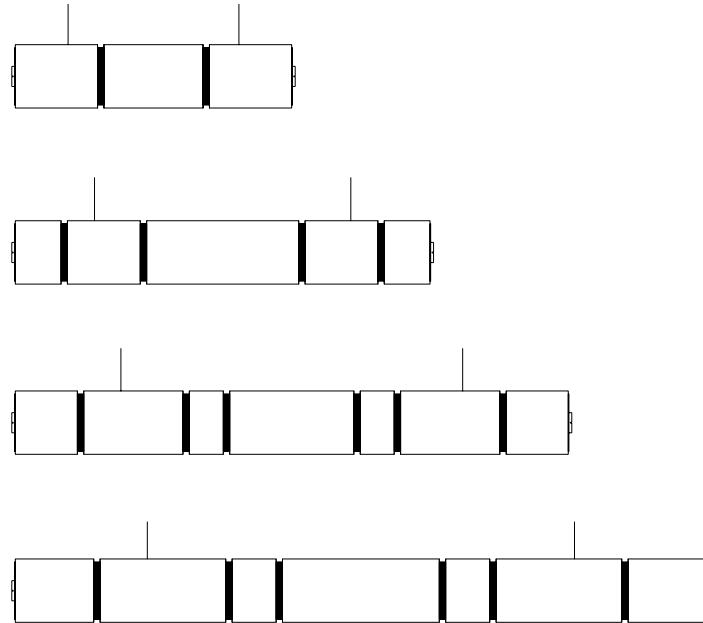

Pendant 8

- 24" L
- 36" L
- 48" L
- 60" L

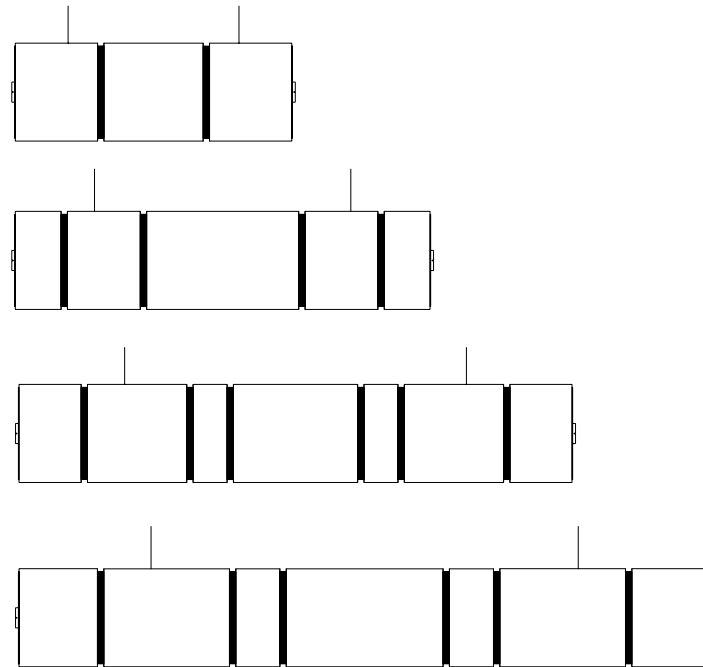

Form 5 8 Collection
60 Pendant
Mood: "Interesting"
© Stackabl

Single Pendant Form 5 and 8 Vertical / Vertical with Downlight



Pendant 5

- 12" H
- 24" H
- 36" H
- 48" H

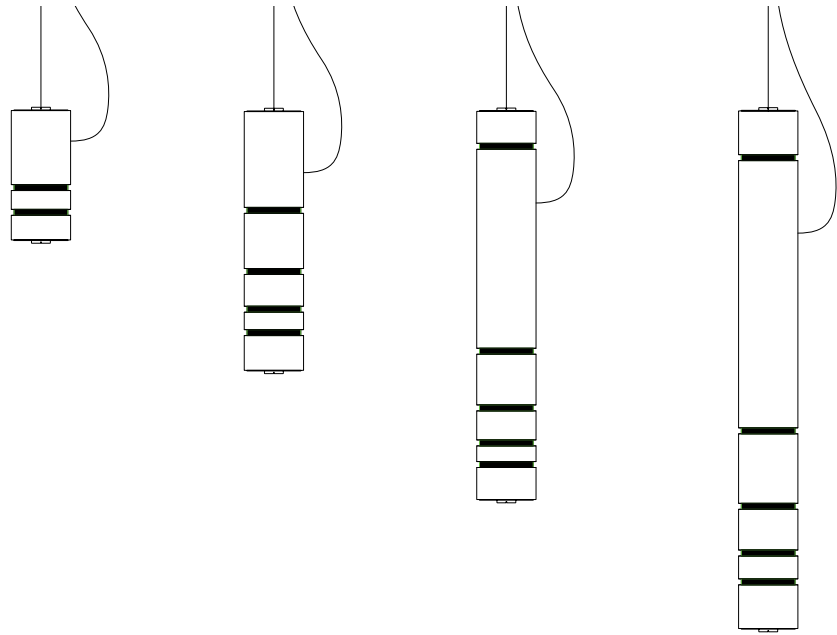

Pendant 5 with Downlights

- 12" H
- 24" H
- 36" H
- 48" H

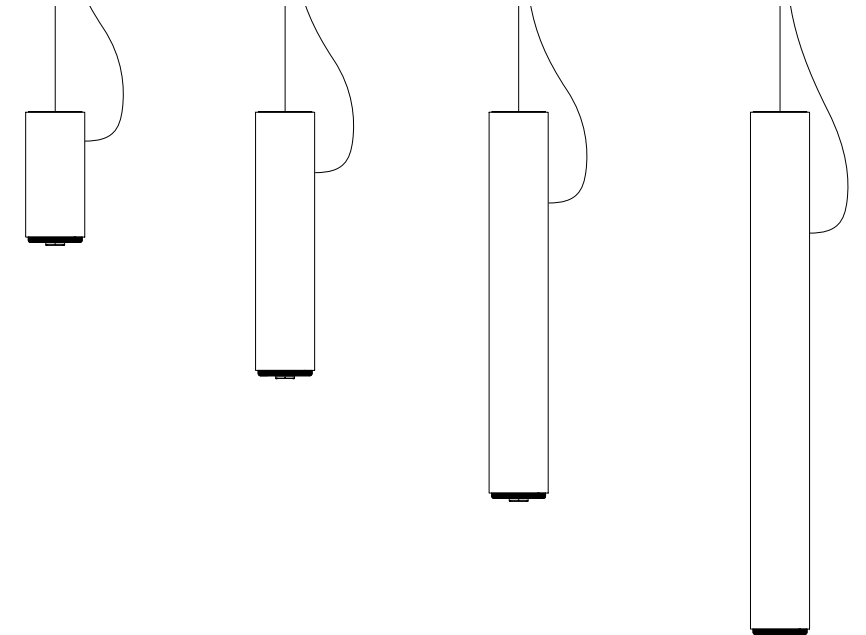

Pendant 8

- 12" H
- 24" H
- 36" H
- 48" H

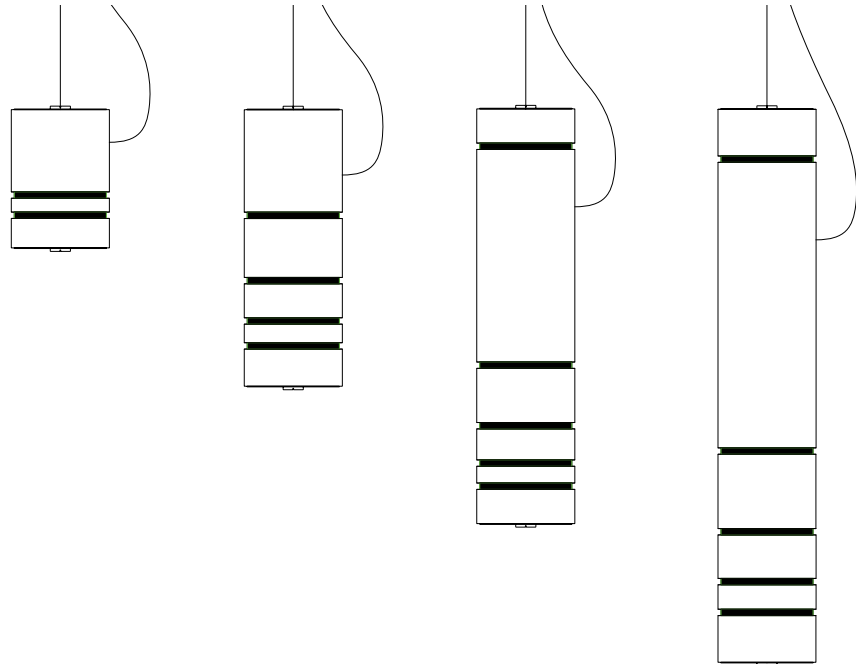

Pendant 8 with Downlights

- 12" H
- 24" H
- 36" H
- 48" H

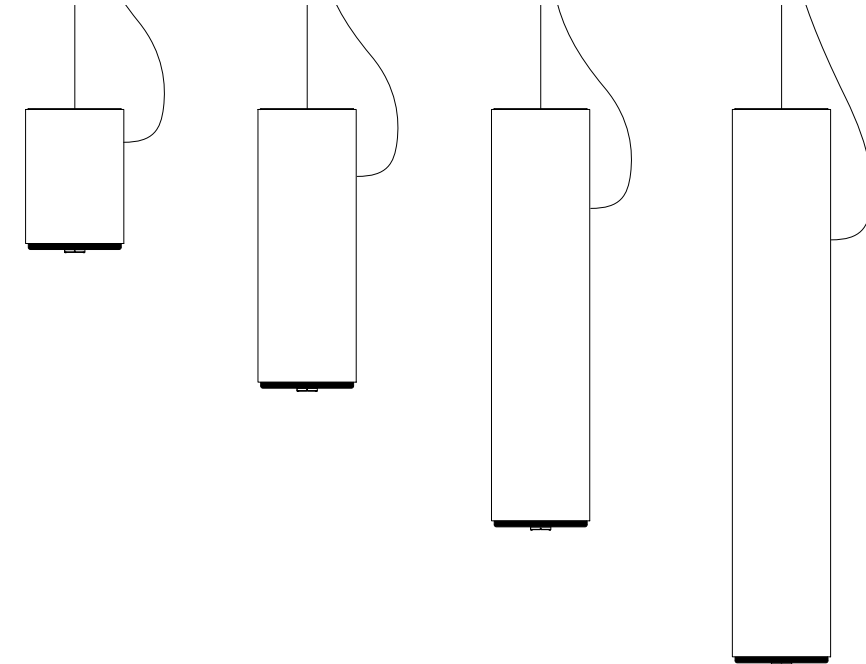

Single Pendant - Form 58 / Form 58 with Downlight

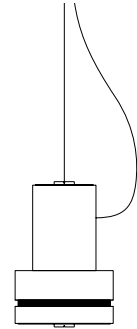

Pendant 58
12" H

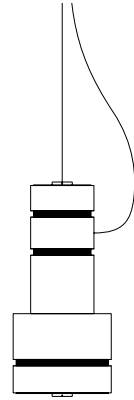

18" H

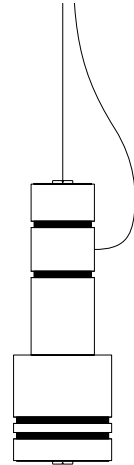

24" H

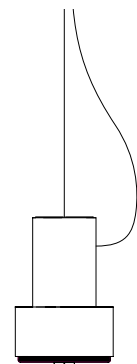

Pendant 58 with Downlight
12" H

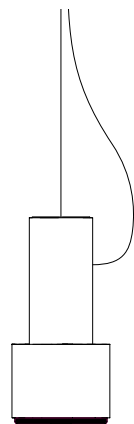

18" H

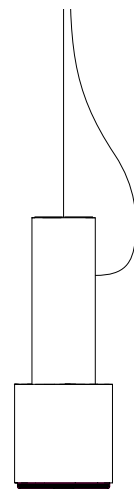

24" H



Form 5 8 Collection
58 Pendant with Downlight
Mood: "Interesting"
© Stackabl

Single Pendant Form 585 / 858

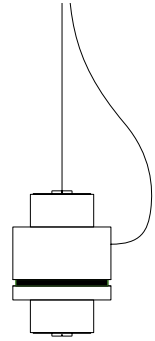
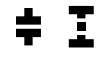

Pendant 585

12" H

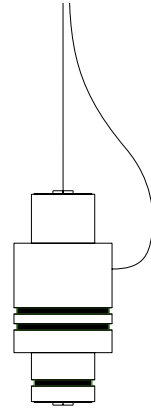

18" H

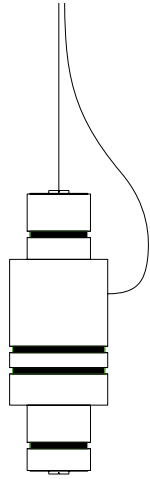

24" H

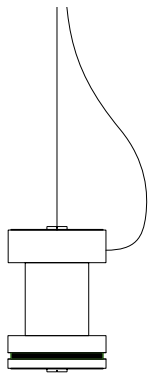

Pendant 858

12" H

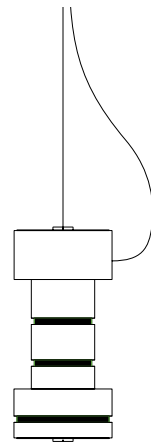

18" H

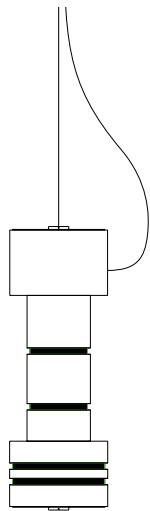

24" H



Form 5 8 Collection
585 Pendant
Mood: "Cute"
© Stackabl



Form 5 8 Collection
858 Pendant
Mood: "Zany"
© Stackabl

Cluster Pendants

SAMPLE CLUSTER

Dimensions vary depending on configuration

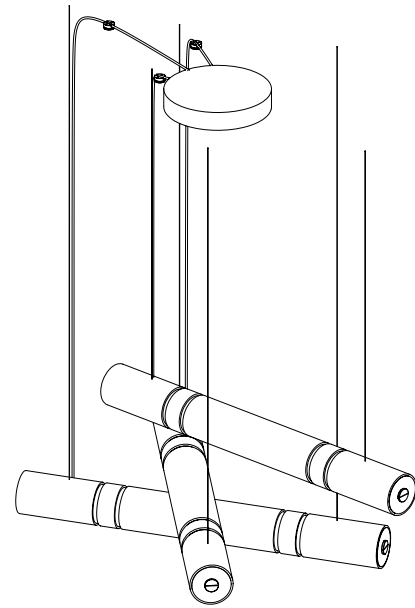

Form 5 8 Collection
© Stackabl

Cluster Pendants

SAMPLE CLUSTER

Dimensions vary depending on configuration

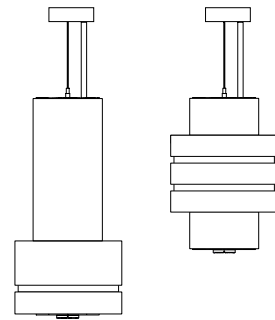

Form 5 8 Collection
Pendant with downlight
© Stackabl

Cluster Pendants



SAMPLE CLUSTERS

Dimensions vary depending on configuration

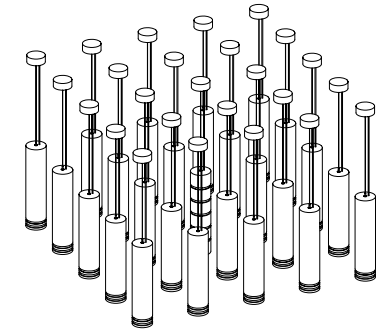
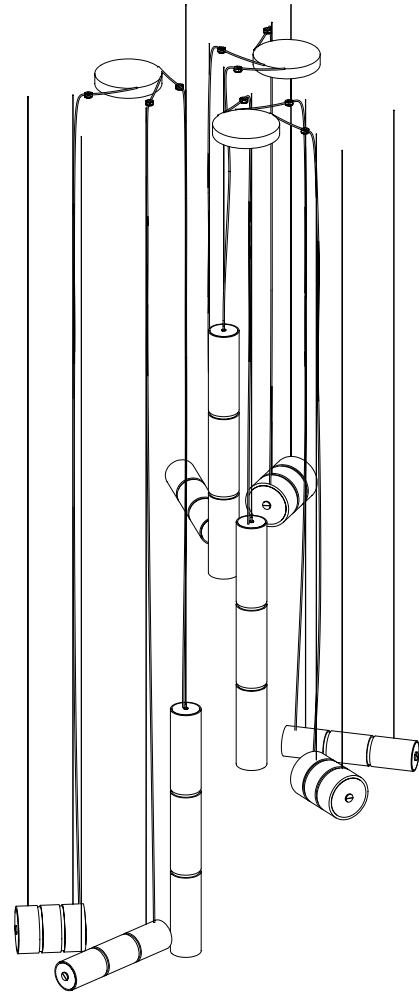
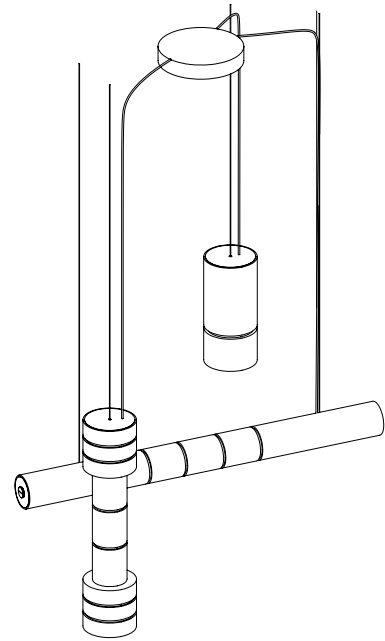

Cluster Pendants

SAMPLE CLUSTERS WITH DOWNLIGHTS

Dimensions vary depending on configuration

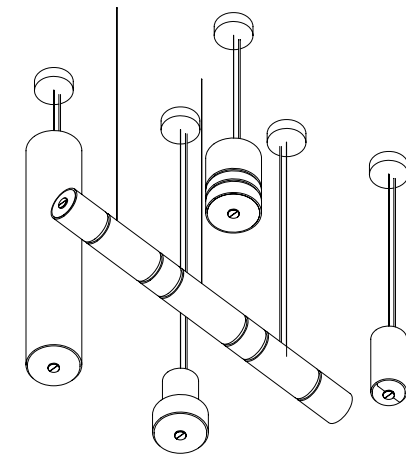
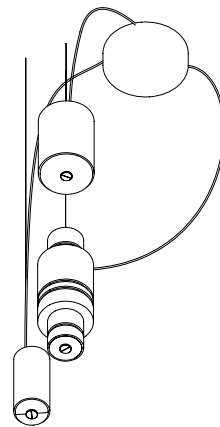
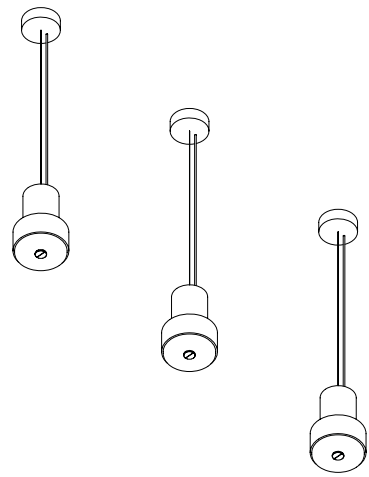

Sconces



SINGLE SCONCES

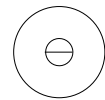

Form 5 Sconce
5-1/2" Dia

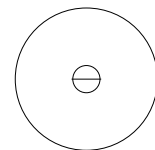

Form 8 Sconce
8-1/2" Dia



Form 5 8 Collection
8 Sconce
Mood: "Interesting"
© Stackabl



CLUSTER SCONCES

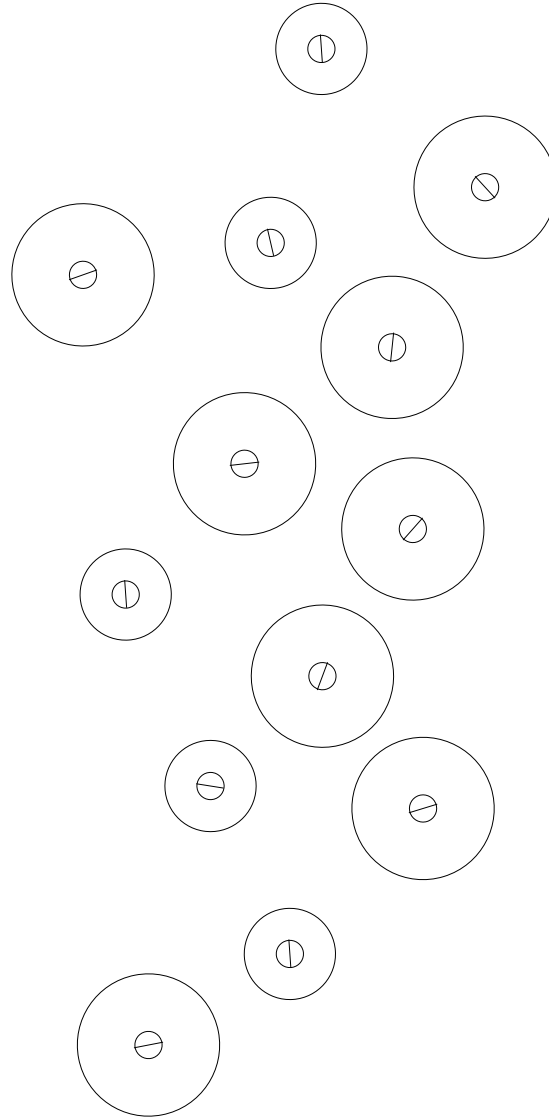
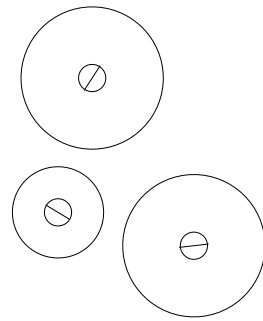
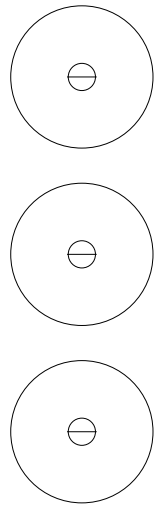

Form 5 8 Sconce Clusters (various)
8-1/2" Dia



Form 5 8 Collection
Sconce Cluster
Mood: "Interesting"
© Stackabl

Canopy Types - Standard

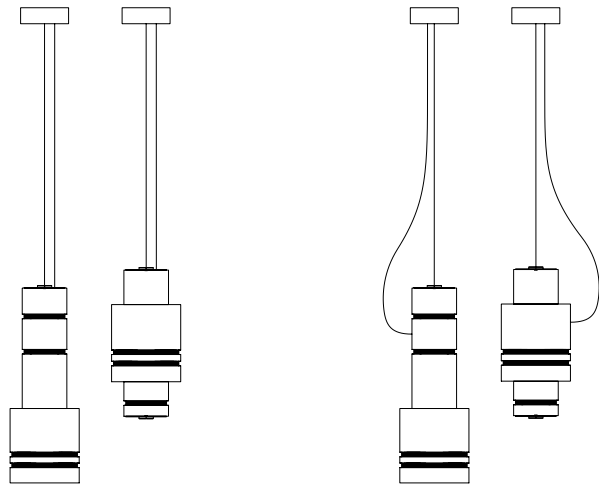

Standard Canopy Concept Diagram
© Stackabl



Standard Canopy
Sample In-situ Visualizations
© Stackabl

Canopy Types - Multi-fixture

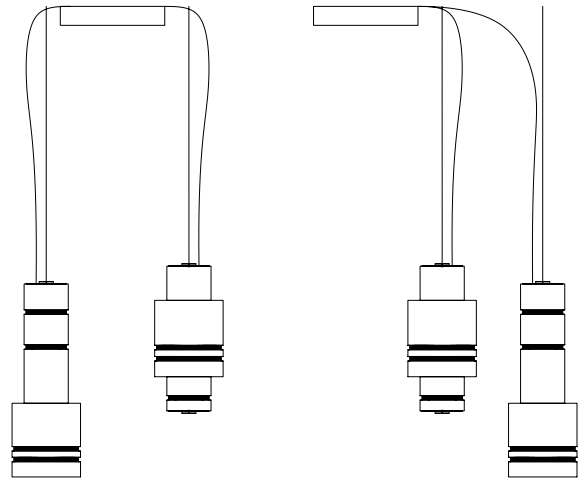

Multi-fixture Canopy Concept Diagram
© Stackabl



Multi-fixture Canopy
Sample In-situ Visualizations
© Stackabl

STACK ABL

CONFIGURATION

Product Builder
Color Moods
Patterning
Color Customization



Tilt + Shift
Tilt 06 Table Lamps
Shown in "Cute", "Zany" and "Interesting" moods mixed pattern
© Stackabl

○○○

Stackabl Product Builder

Here you can customize any of our configurable collections. Select your product, and you will be guided through a short exercise to make your specification selections. Once complete, you can download a custom spec sheet that captures all of your choices.



CONFIGURATION PROCESS

- > Select product
- > Select orientation
- > Select size
- > Select cable out
- > Select performance profile
- > Select color
- > Select pattern
- > Submit

Full model warehouse in universal .3dm format with accurate digital color swatches

Select one color mood and pattern. Don't see something you like? You can customize.

**Tilt 06 and Tilt 11 is available in preset color moods only. Full color customization not available.*

CUTE



Champagner Salbei



Silber Weiß



Sand Dollar Oat



Ceppo Di Mere Champagne



Tan

INTERESTING

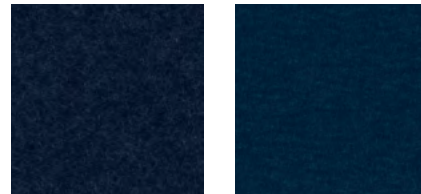

Indigo Traube



Stahl Petrol



Lagune Ozean



Cristallo White Clear

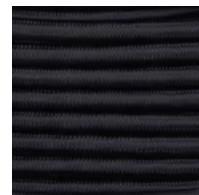

Black

ZANY



Weinrot Aubergine



Terracotta Maigrün

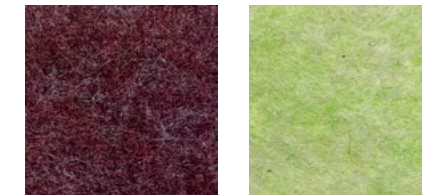

Maroon Honeydew

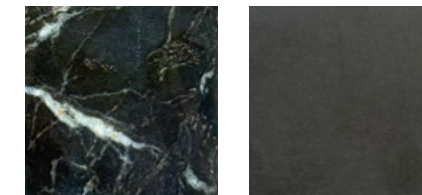

Belvedere Black



Chestnut

Color Moods



CUTE



INTERESTING



ZANY

Form 5 8 Collection
585 Pendants
© Stackabl

**Not available for Tilt 06 and Tilt 11*



BLOCKING



SEMI-BLOCK



MIXED

Form 5 8 Collection
8 Pendants
Mood: "Cute"
© Stackabl

Color Customization

**Not available for Tilt 06 and Tilt 11*

Select as many felt and PET colors as you'd like:

Natural Felted Merino Wool - Premium Remnant (Base) Colors (mix of 3 and 5mm)



- Orange
- Weinrot
- Flieder
- Petrol

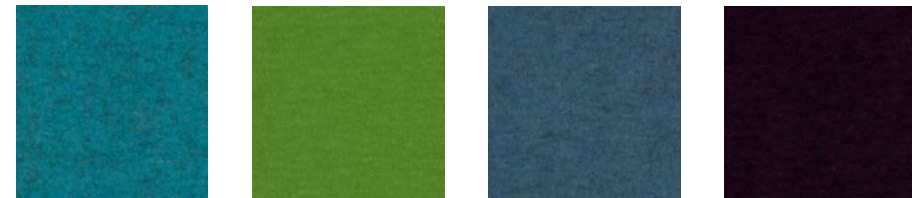

- Lagune
- Maigrün
- Stahl
- Aubergine



- Indigo
- Ozean
- Salbei
- Traube



- Weiß
- Hellrot
- Terracotta
- H'Blau



- Silber
- Champagner
- Eis
- Gletscher

60% Recycled Polyethylene Terephthalate (PET) Colors (9mm)

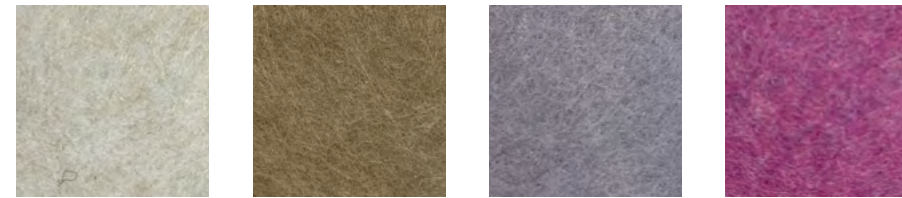

- Sand Dollar
- Oat
- Periwinkle
- Lilac



- Midnight Blue
- Orange
- Salmon
- Pink

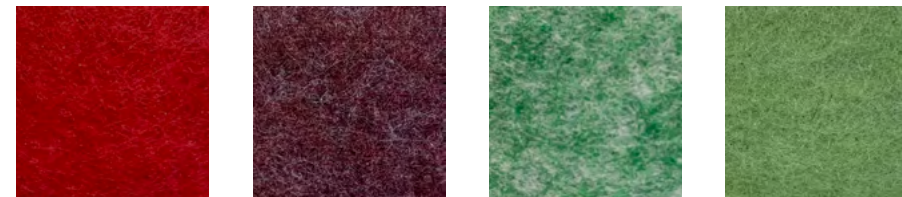

- Red
- Maroon
- Heather Green
- Pear



- Stone
- Lemon
- Yellow
- Honeydew

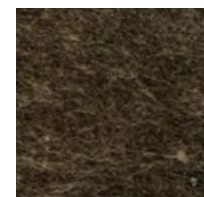



- Earth Brown

Color Customization

**Not available for Tilt 06 and Tilt 11*

Choose one of the following materials:

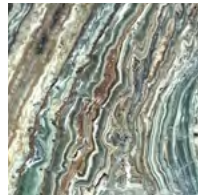
Natural Stone (for floor lamp base only)

- 
 Cristallo White
- 
 Esmarelda
Green Onyx
- 
 Belvedere
- 
 Ceppo Di Mere

Metal (for tuft and/or floor lamp base) [Choose one]

- 
 Black
- 
 Clear
- 
 Champagne

Cork (Tilt + Shift only)

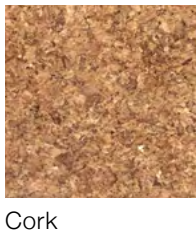





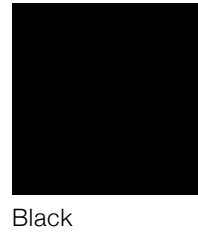

Cork

USB-C Cable (for floor lamps only)

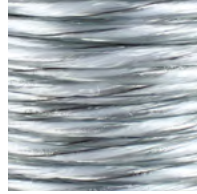

Black

Cable (for pendants only)

- 
 Gold
- 
 Black
- 
 White
- 
 Orange
- 
 Off-white
- 
 Blue
- 
 Clear
- 
 Chestnut



Form 5 8
Custom Pendant Cluster
Configured 06.12.23
Photo © Patrick Biller



Form 5 8
Custom Pendant Cluster
Configured 02.12.24
Photo © Arash Moallemi



Form 5 8
5 Pendant
Configured 11.14.23
Photo © Arash Moallemi

STACK ABL

TECH SPECS

Lighting Performance Profile
Lighting Acoustic Data

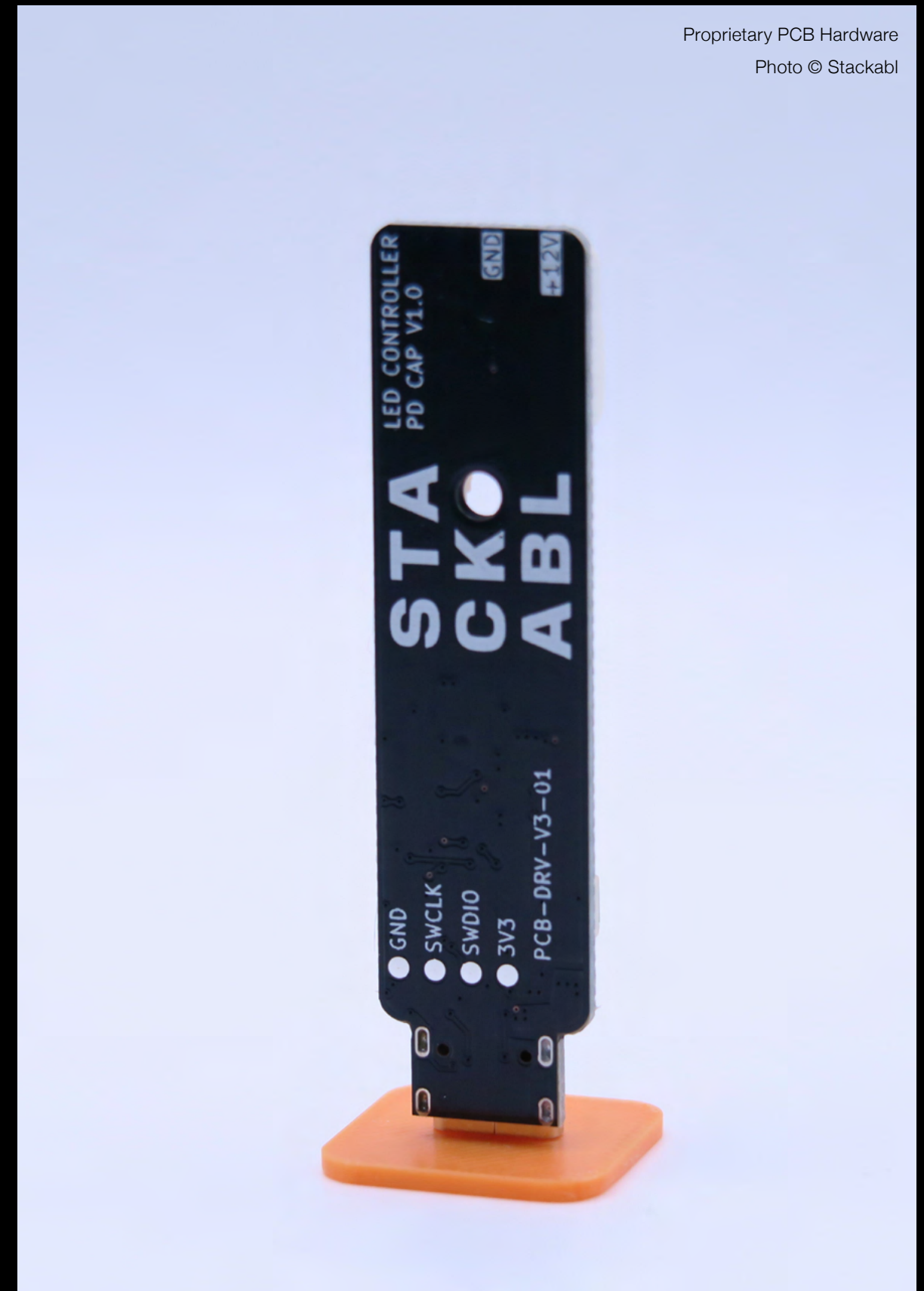

Lighting Performance Profile

CERTIFICATION

ETL certified (UL equivalency)

Dry indoor use only

POWER

Power Supply - Lamps:

- “Cellphone-style” plug-in driver (provided), fabric-wrapped USB-C wire

Power Supply - Pendants / Downlight Pendants / Sconces:

- 12 VDC output Class 2 constant voltage integral power supply
- Integral power supply in Standard Canopy can support up to 10 light discs
- Integral power supply in Multi-fixture Canopy can support up to 25 light discs
- Remote drive options upon request

Controls - Lamps:

- Touch on/off/dim

Controls - Pendants / Downlight Pendants / Sconces:

- 120/227 V input, TRIAC, ELV, 0-10 dimming
- Casambi, DALI, Lutron Compatible

Input Voltage - Lamps:

- USB-C PPS 12 VDC

Input Voltage - Pendants / Downlight Pendants / Sconces:

- 120 VAC (277 VAC upon request)

Lamping - Standard (side-emitting discs):

3.7 W per 5” light disc / 7.4 W per 8” light disc, CRI 90, L80 50,000 hours

Lamping - Downlight Disc (underside-mounted):

- 5” Downlight - SO: 2.8 W / HO: 5.7 W, CRI 90, L80 50,000 hours
- 8” Downlight - SO: 5.7 W / HO: 11.4 W, CRI 90, L80 50,000 hours

Lumens Delivered - Standard (side-emitting discs / sconces):

350 lm per 5” light disc / 585 lm per 8” light disc

Light Disc Temp:

2200 K / 2700 K / 3000 K / 3500 K

ACOUSTICS

Felt NRC: 0.2

PET NRC: 0.3

ASSEMBLED IN TORONTO, CANADA

Night City Scape Floor Lamps

USBC plug-in

Photo © Patrick Biller



Lighting Acoustic Data

ACOUSTIC LIGHTING WITH REAL SOUND REDUCTION

Stackabl fixtures deliver meaningful sound absorption, from 0.19 to 3.35 sabins per piece. Even at the low end, sabin values make an audible difference, softening echo and improving clarity in residential and commercial rooms. At the high end, our fixtures perform on par with dedicated acoustic panels. Used in multiples, or paired with rugs and upholstered elements, they become a highly effective tool for reducing reverberation and improving overall comfort.

Because our system also provides functional lighting and customizable color, designers can address acoustics, illumination, and visual identity with one solution. Budgets can be shared across lighting, acoustics, and even art in some cases, giving specifiers maximum flexibility.

Height (in)	Diameter (in)	Surface Area (sq ft)	NRC Rating (Felt)	Sound Absorption (Sabins) (Felt)	NRC Rating (PET)	Sound Absorption (Sabins) (PET)
PENDANTS / PENDANTS WITH DOWNLIGHTS 5						
24	5.5	2.88	0.2	0.58	0.3	0.86
36	5.5	4.32	0.2	0.86	0.3	1.30
48	5.5	5.76	0.2	1.15	0.3	1.73
60	5.5	7.2	0.2	1.44	0.3	2.16
PENDANTS / PENDANTS WITH DOWNLIGHTS 8						
24	8.5	4.45	0.2	0.89	0.3	1.34
36	8.5	6.68	0.2	1.34	0.3	2.00
48	8.5	8.9	0.2	1.78	0.3	2.67
60	8.5	11.12	0.2	2.22	0.3	3.34

Height (in)	Diameter (in)	Surface Area (sq ft)	NRC Rating (Felt)	Sound Absorption (Sabins) (Felt)	NRC Rating (PET)	Sound Absorption (Sabins) (PET)
PENDANTS 858						
12	Mixed	1.81	0.2	0.36	0.3	0.54
18	Mixed	2.71	0.2	0.54	0.3	0.81
24	Mixed	3.62	0.2	0.72	0.3	1.09
PENDANTS / PENDANTS WITH DOWNLIGHTS 58						
12	Mixed	1.73	0.2	0.35	0.3	0.52
18	Mixed	2.61	0.2	0.52	0.3	0.78
24	Mixed	3.45	0.2	0.69	0.3	1.04
PENDANTS 585						
12	Mixed	1.84	0.2	0.37	0.3	0.55
18	Mixed	2.86	0.2	0.57	0.3	0.86
24	Mixed	3.76	0.2	0.75	0.3	1.13
SCONCES						
N/A	5.5	0.519	0.2	0.1	0.3	0.16
N/A	8.5	0.941	0.2	0.19	0.3	0.28
LAMPS - COLUMN						
48	Mixed	8.08	0.2	1.62	0.3	2.43
60	8.5	11.12	0.2	2.22	0.3	0.86
85	5.5	10.19	0.2	2.04	0.3	3.06
LAMPS - TILT						
06	5.5	0.49	0.2	0.1	0.3	0.15
11	8.5	1.2	0.2	0.24	0.3	0.44
LAMPS - SHIFT						
20	5.5	1.47	0.2	0.29	0.3	0.36
36	8.5	4.33	0.2	0.87	0.3	1.3
46	8.5	3.83	0.2	0.77	0.3	1.15

STACK ABL

Stackabl x Maison Gerard
Feat. Jamei Drake and Caleb Anderson
Photo © Luxe Magazine

ENVIRONMENTAL CERTIFICATIONS

Embedded Material Certifications
Product Certifications
Certification Support
Red List Compliance



Embedded Material Certifications

3mm and 5mm felted Merino wool

Stackabl's felted Merino wool is manufactured using solely **natural ingredients**, including sheep's wool, water, and plant-based textile dyes that are safely disposed of in wastewater. In addition, ten 100 percent natural colors are composed of wool and water exclusively. It also has the following qualities and certifications:

- Wool felt is **100 percent biodegradable**
- 100 percent **VOC free**, no chemical irritants
- Oeko-Tex Standard 100 Certified Product Class II
- **Living Building Challenge Criteria Compliant**
- LEED MR credit 6

Embedded Material Certifications

Class C PET

Acoustic board is made with **60 percent recycled fibers**. These boards not only contribute to reducing waste but are also sourced regionally, minimizing the carbon footprint associated with transportation.

- 60 percent recycled water bottle plastic

Product Certifications

EPD Ready, Verified Very Low-Carbon Performance

Stackabl's product-specific Environmental Product Declaration confirms very low embodied carbon performance relative to comparable decorative lighting fixtures with integrated LED systems. This outcome is driven by a material strategy centered on upcycled inputs and efficient, localized manufacturing, resulting in minimal embodied emissions from the product's structural and acoustic components.

As with all lighting products, integrated LED and electronic components inherently carry embodied carbon. Within this unavoidable constraint, Stackabl's system performs at the very low end of the decorative lighting category, with the majority of remaining cradle-to-gate emissions attributable to electronics rather than materials, fabrication, or assembly.

The verified EPD dataset provides transparent, third-party-reviewed environmental data and may be used to support LEED, WELL, and other performance-based sustainability pathways, positioning Stackabl as a materially efficient, low-impact option for architectural lighting applications.

Certification Support

Stackabl product materials and performance attributes can support projects in pursuing LEED and WELL credits.

They can contribute to:

LEED:

- Energy Performance
- Recycled Material Sourcing
- Material Ingredients
- Interior Lighting Quality
- Acoustic Performance
- Innovation
- Light Pollution Reduction

WELL:

- Light
- Sound
- Materials
- Innovation

*Actual points depend on project use, performance, and documentation.

Stackabl provides **complete material transparency** through published data sheets and can support material-health documentation as required.

CORE MATERIALS

Wool felt: Red List Approved

Cork: Red List Approved

PET: Not restricted under the Red List; full resin and additive data available

OTHER COMPONENTS

Cast acrylic (PMMA): Not a Red List polymer, compliant when free of halogenated flame retardants

Anodized aluminum: Locally anodized using non-hexavalent processes; Red List compliant

Electrical components: Some elements (wiring, PCBs, solders) may fall under LBC Temporary Exceptions.

We prioritize RoHS-compliant suppliers and can provide documentation upon request.

STA CK ABL

CONSTRUCTION AND INSTALLATION

Pendant Construction
Installation Components
Pendant Mounting
Canopy Assembly
Pendant Wiring



Stackabl x Maison Gerard
Feat. Anthony Frank Keeler - Hombre Short, Hombre Long
Photo © Patrick Biller

Pendant Construction

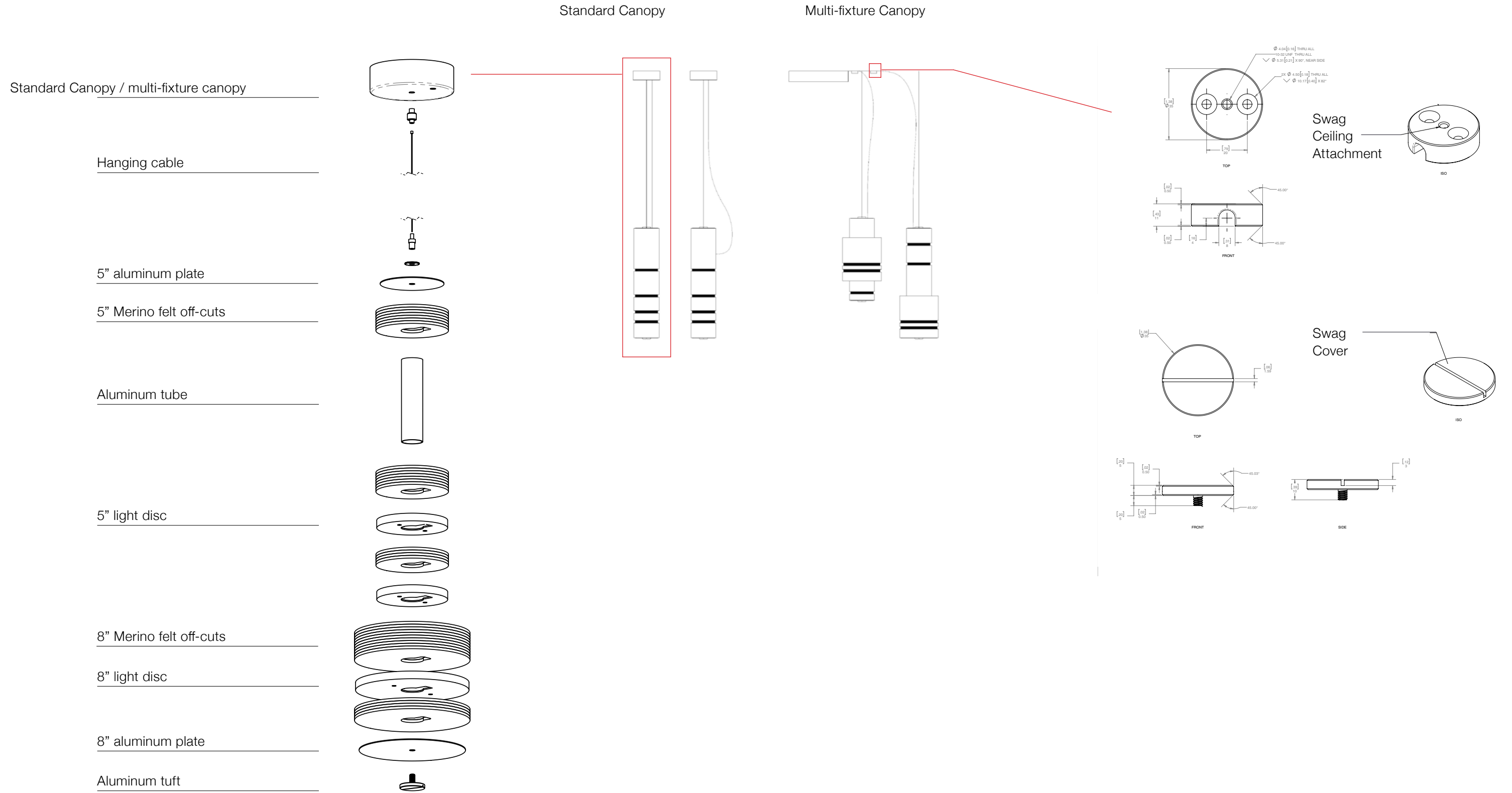

Installation Components

Standard Canopy Components

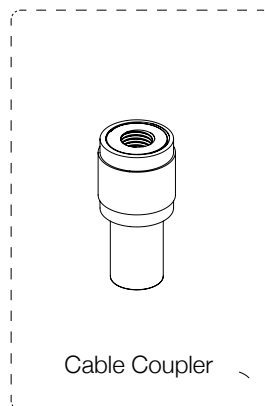
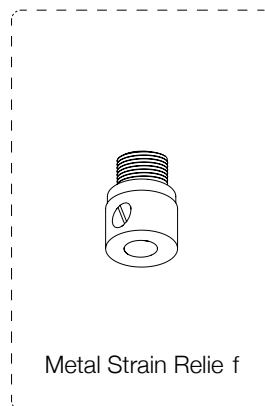
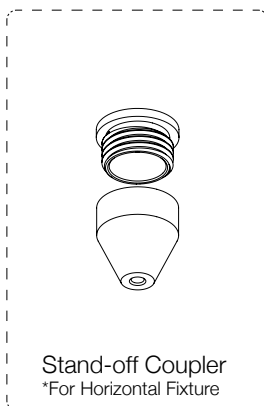
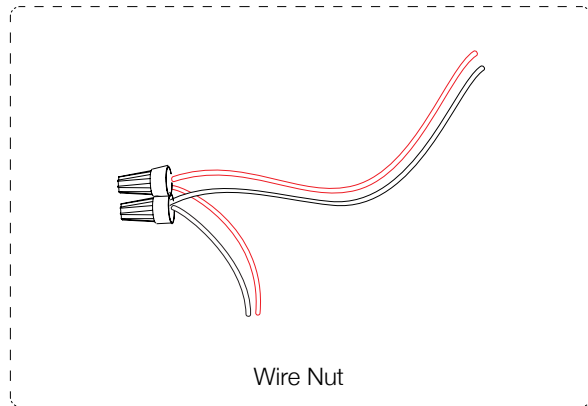
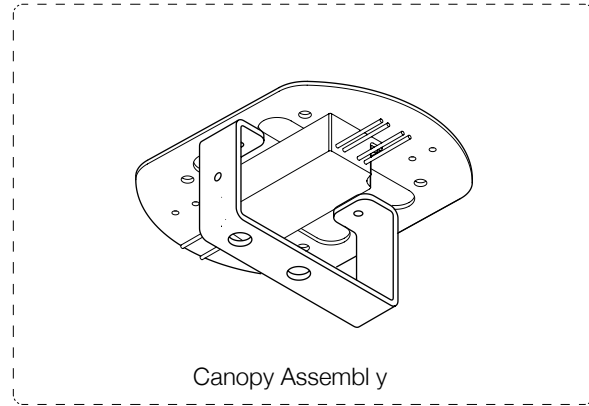
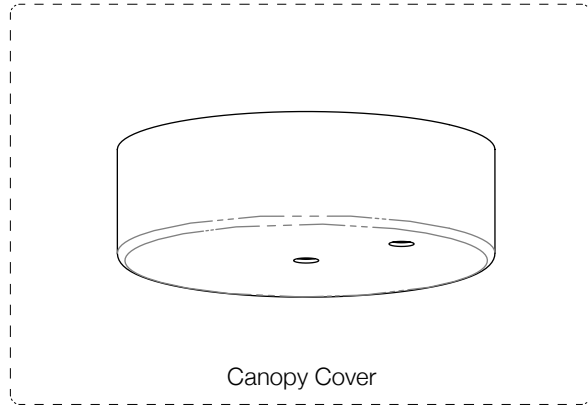

Multi-fixture Canopy Components

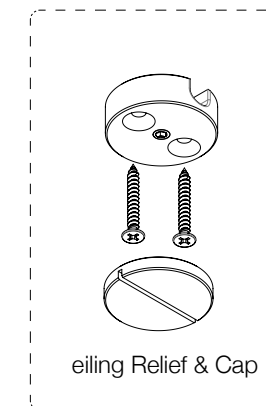
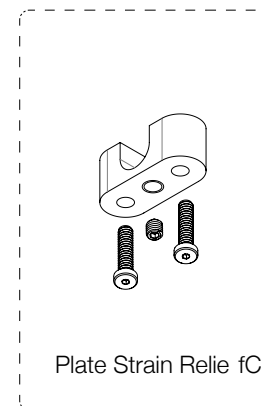
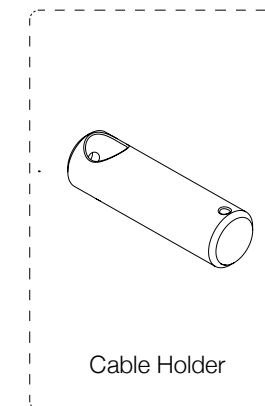
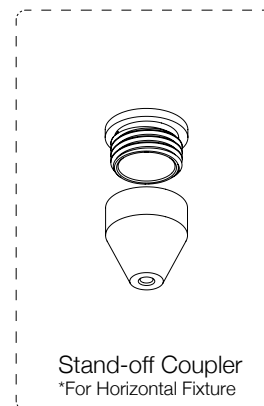
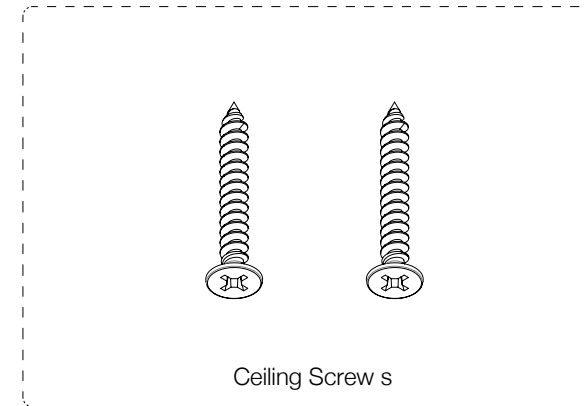
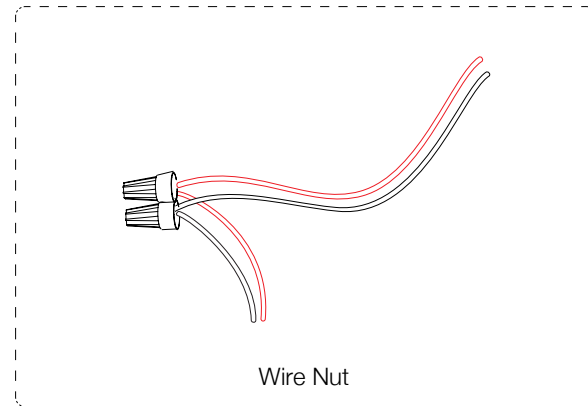
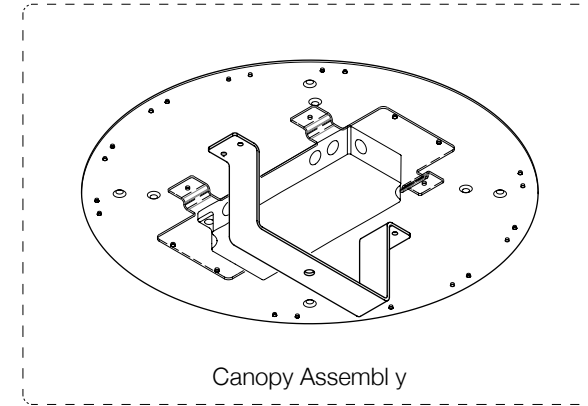
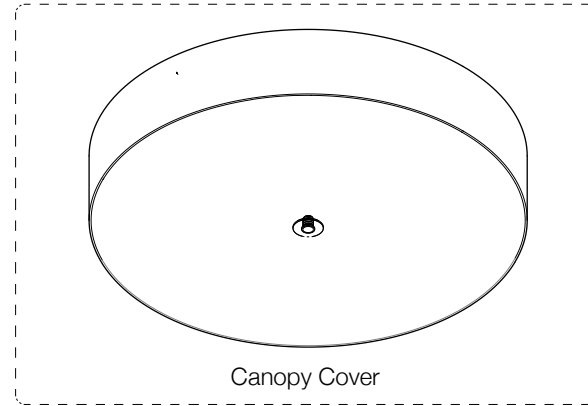

Canopy Assembly

STANDARD CANOPY

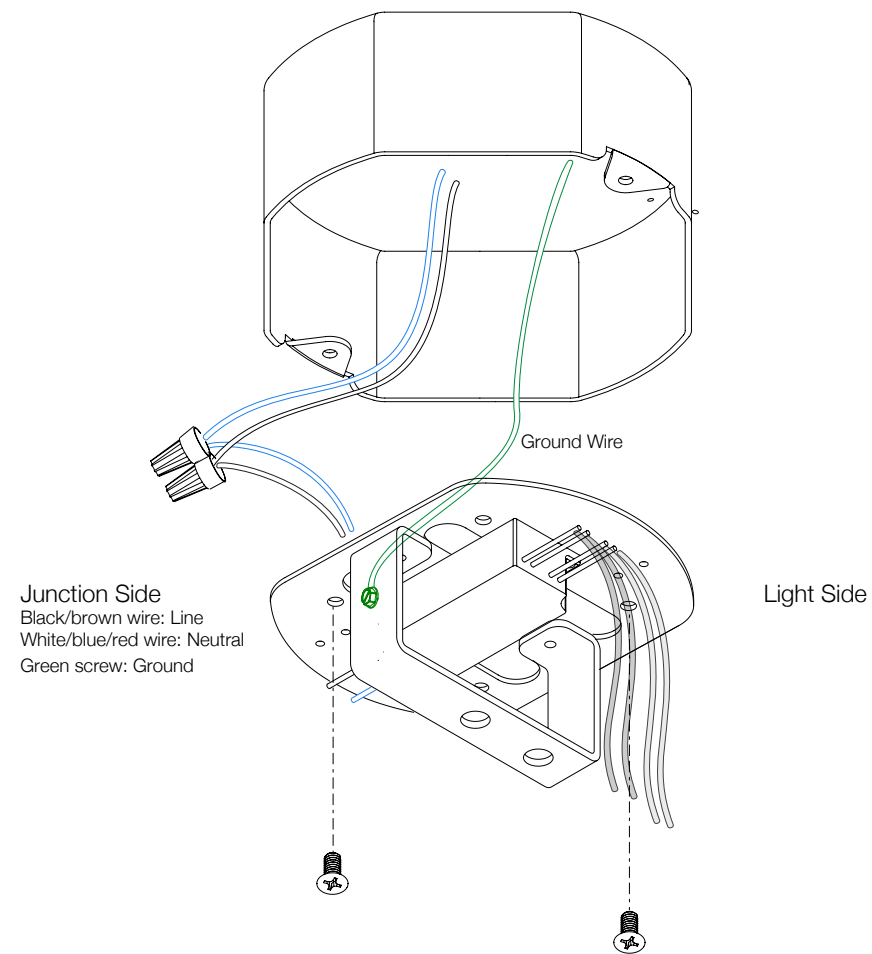

MULTI-FIXTURE CANOPY

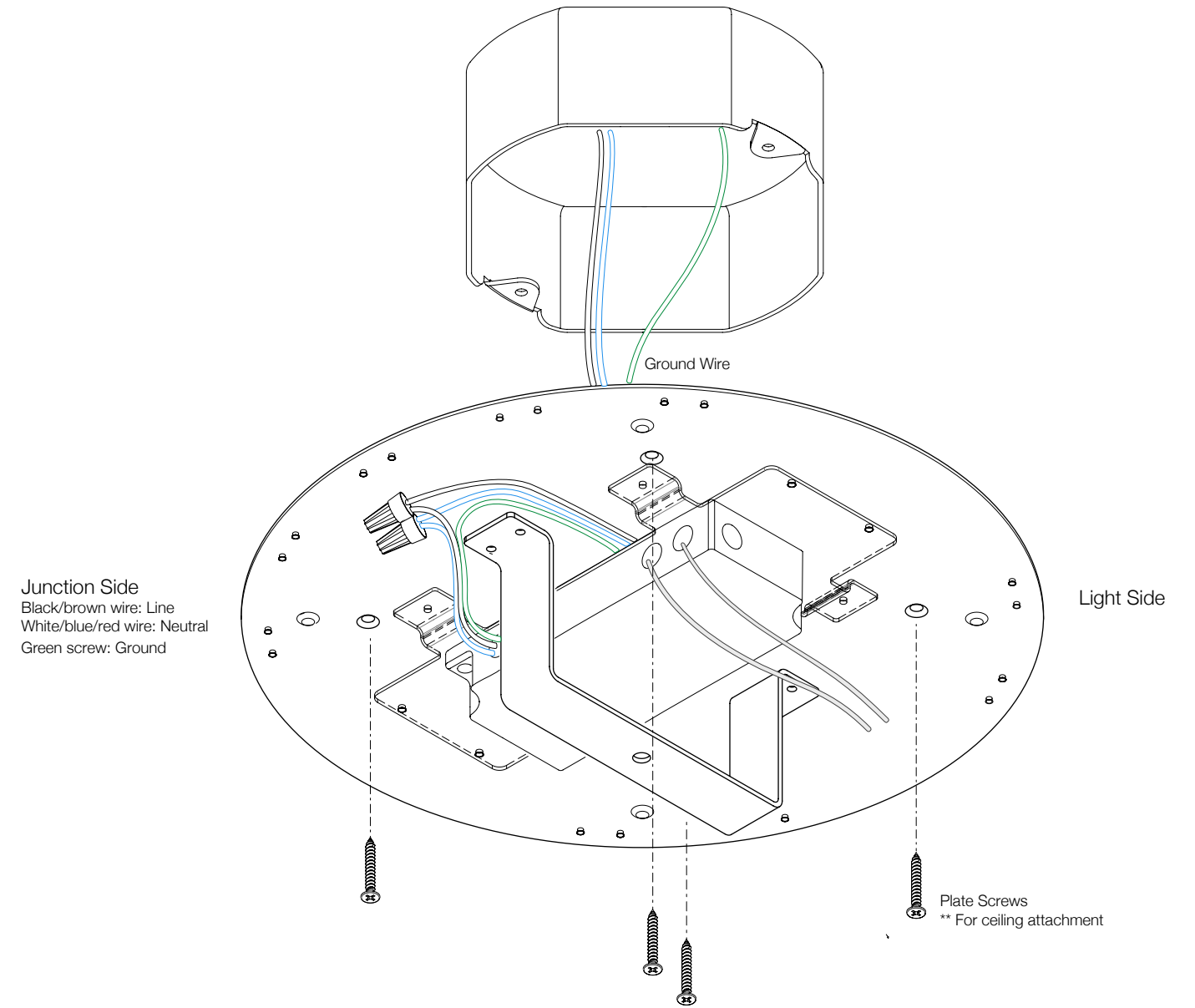

Pendant Mounting

Vertical Fixture

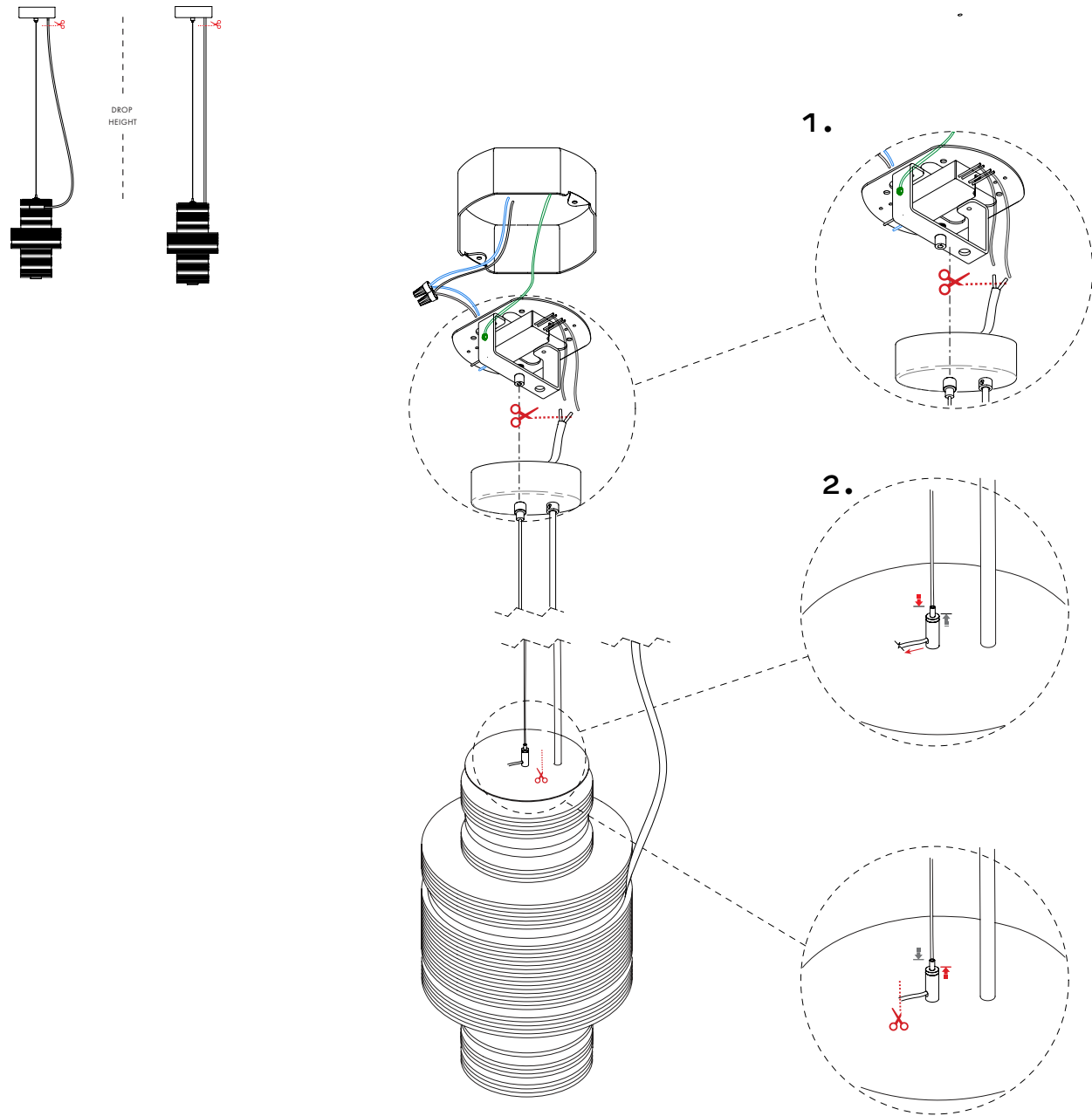

Horizontal Fixture

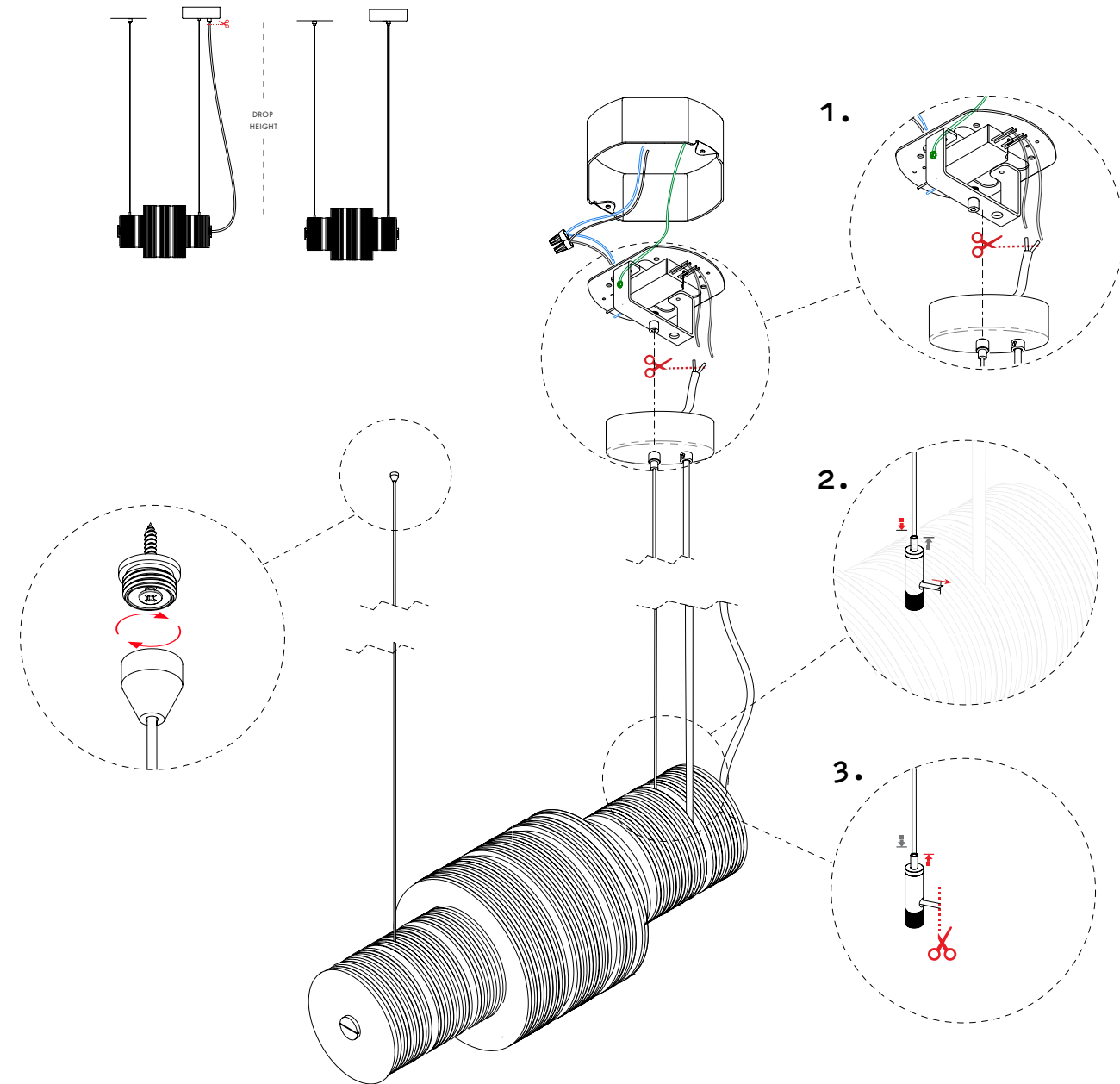

Pendant Wiring

Standard Fixture Power Cable Wiring

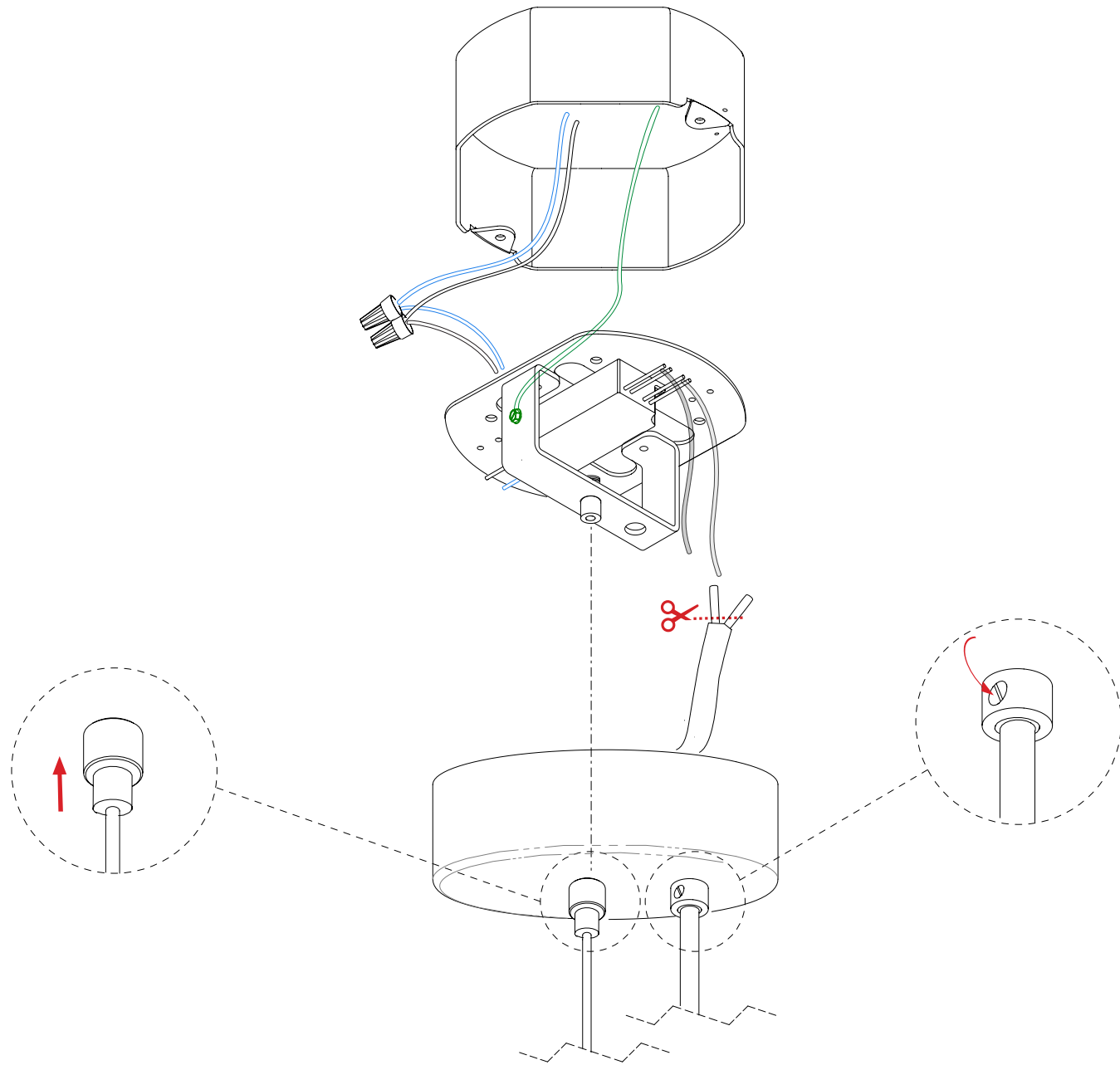

Multi-fixture Power Cable Wiring

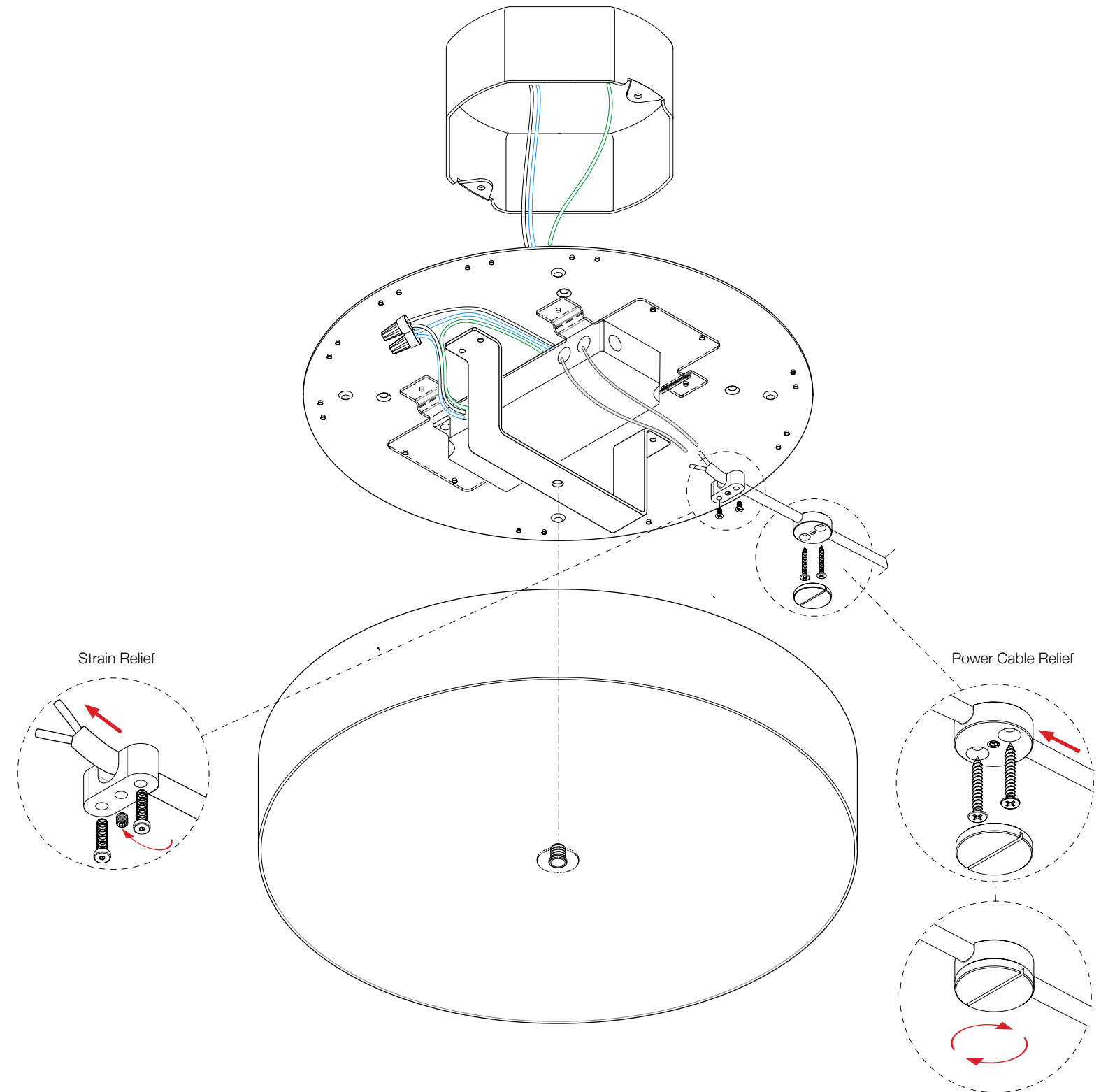

**STA
CK
ABL**

CARE AND WARRANTY

Care and Maintenance

Warranty Coverage

Sales Terms & Conditions



Form 5 8 Collection

8 Pendant

Photo © Stackabl

Care and Maintenance

TEXTILE

Lint roll occasionally to remove general air-borne debris. Should soiling occur, spot clean with mild soap and lukewarm water. Avoid aggressive rubbing as this can continue the felting process and change the surface appearance of the felt.

ALUMINUM, ACRYLIC, AND STONE

Wipe occasionally to remove general air-borne debris. Should soiling occur, clean gently with an ammonia-free glass cleaner.

Warranty Coverage

COVERAGE

Stackabl provides a limited three-year warranty to the original purchaser. It covers defects in material and workmanship under normal household use. The warranty is not transferable.

NOT COVERED

- Improper installation or assembly
- Natural variations in color, finish, or materials
- Fading from sunlight
- Weather exposure or improper environment
- Normal wear and tear or patina changes
- Cuts, scratches, or surface damage
- Damage from negligence, improper cleaning, misuse, accident, or commercial use
- Costs related to installation, removal, packing, or shipping
- Variations in size or materials inherent to our process

SERVICE

To request service, contact Stackabl via our website, email, or phone and provide proof of purchase. Stackabl will determine whether to repair, replace, or provide a substitute for any eligible item.

LEGAL

This warranty replaces all other warranties. Implied warranties are limited to three years. Remedies are limited to repair or replacement. Incidental or consequential damages are not covered. Rights may vary by state.

Sales Terms & Conditions

These **Sales Terms & Conditions** govern the sale of all Stackabl furniture and lighting products unless otherwise agreed in writing. These terms operate in conjunction with Stackabl's Three (3) Year Limited Warranty, which governs product defects, coverage, and remedies.

Payment

Stackabl accepts payment by wire transfer, ACH (where applicable), and major credit cards including Visa, Mastercard, and American Express. Full payment is charged when the order is accepted.

Currency

All orders are billed in U.S. Dollars unless otherwise stated. Stackabl is not responsible for currency exchange rates or fees applied by financial institutions.

Pricing

All prices are subject to change without notice. Prices exclude shipping, crating, brokerage, duties, taxes, and installation unless otherwise specified in writing.

Taxes and Duties

All orders ship from Toronto, Ontario, Canada. For shipments within Canada and the United States, applicable duties and brokerage may be included in the quoted shipping charge where specified. For shipments outside of Canada and the United States, any customs duties, taxes, or import fees are assessed once the shipment reaches its destination country and are the responsibility of the purchaser. Stackabl does not assume responsibility for these charges.

Production Lead Times

Production lead times begin upon receipt of full payment. All lead times are estimates only and exclude holidays and transit time. Stackabl is not responsible for delays resulting from supply chain disruptions, carrier delays, customs clearance, or circumstances beyond its reasonable control.

Shipping

Orders are shipped from Toronto, Ontario, Canada via courier or freight carrier depending on size and destination. Shipping transit times are estimates only and are not guaranteed. Stackabl is not responsible for delays in shipment or delivery, including delays caused by carriers or customs clearance.

Shipping Restrictions

Stackabl ships worldwide. We do not ship to P.O. boxes or APO/FPO addresses. Stackabl is unable to ship to any country subject to applicable trade restrictions or sanctions.

Carrier Loss

If a shipment has not been received, notice must be provided within thirty (30) days of the original ship date.

Shipping Damage

Damages caused in transit must be documented and reported in writing within ten (10) business days of delivery. Original packaging must be retained in order to support a claim.

Installation

Lighting products must be installed by a licensed electrician in accordance with applicable local codes. Furniture and lighting products must acclimatize to the installation environment prior to installation. Improper installation or assembly by the purchaser or a related third party may affect product performance and warranty coverage.

Product Variation

Each product is individually assembled and finished by hand. Subtle variations in color and form are part of the natural character of our work and are not considered defects. Variation between samples, images, and delivered product is to be expected.

Returns

Eligible standard items may be returned for credit to the original

payment method if received within fourteen (14) days of delivery. Return shipping costs are the responsibility of the purchaser. Returns requested between fifteen (15) and forty-five (45) days from delivery may be accepted at Stackabl's discretion and may be subject to a fifteen percent (15%) restocking fee. Returns beyond forty-five (45) days from delivery are politely declined. All returned items must be in original, uninstalled, unused condition and in original packaging. Custom, modified, made-to-order, and contract products are final sale and are not eligible for return. Return authorization must be obtained prior to shipping any product back to Stackabl.

Warranty

Stackabl products are covered by a Three (3) Year Limited Warranty. For full details regarding coverage, exclusions, and remedies, please refer to the warranty document.

Limitation of Liability

To the extent permitted by law, Stackabl's liability shall be limited to the purchase price of the product giving rise to the claim. Stackabl is not responsible for any costs related to installation, re-installation, removal, or repair.

Customer Service

For assistance, please contact service@stackabl.shop.

Termination and Cancellation

Stackabl reserves the right, at its sole discretion, to decline or cancel any order or refuse service at any time.

General

These Terms & Conditions apply except where otherwise agreed in writing. Stackabl reserves the right to update these terms from time to time.

STACK ABL

Maison Gerard x Stackabl
Furniture Collection
Photos © Yuzu Magazine



DESIGN COLLABORATIONS

- 2021 Maison Gerard - Furniture
- 2022 Maison Gerard - Lighting
- 2023 Jeff Forrest
- 2023 Mindy Solomon
- 2024 Benoist F. Drut
- 2025 Rockwell Group

Stackabl x _____

We partner with leading designers each year to gain insights from their practice and strengthen our own design thinking. These collaborations also help amplify our messaging and expand brand awareness. Since Stackabl launched, we have released at least one named collaboration annually.

2021 Stackabl x Maison Gerard - Furniture

2021

Stackabl x Maison Gerard

Furniture Collection

FEATURING

Jamie Drake and Caleb Anderson
Bill Georgis and Ilya Mirgorodsky
Benoist F. Drut
Elena Frampton
Alexandra Champalimaud
Laura Kirar



Winter Show
660 Madison Avenue | Window by Young Huh
April 1 – 10, 2022
Photo © Maison Gerard

2021 Stackabl x Maison Gerard - Furniture



"Madame"
Feat. Jamie Drake and Caleb Anderson
Photo © Sean McBride for Maison Gerard

2021 Stackabl x Maison Gerard - Furniture



"Querelle"
Feat. Bill Georgis and Ilya Mirgorodsky
Photo © Sean McBride for Maison Gerard

2021 Stackabl x Maison Gerard - Furniture

MAISON GERARD

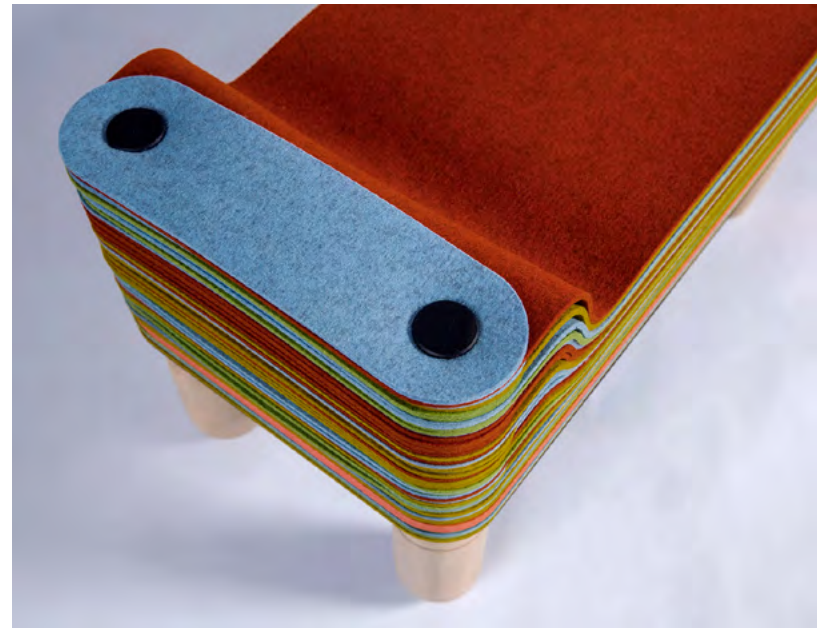

"Maxine"
Feat. Benoist F. Drut
Photo © Sean McBride for Maison Gerard

2021 Stackabl x Maison Gerard - Furniture

Stackabl



"Fast Lane"
Feat. Elena Frampton
Photo © Sean McBride for Maison Gerard

2021 Stackabl x Maison Gerard - Furniture



"Raki"
Feat. Alexandra Champalimaud
Photo © Sean McBride for Maison Gerard

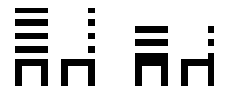

"Dulces"
Feat. Laura Kirar
Photo © Sean McBride for Maison Gerard



2022 Stackabl x Maison Gerard - Lighting

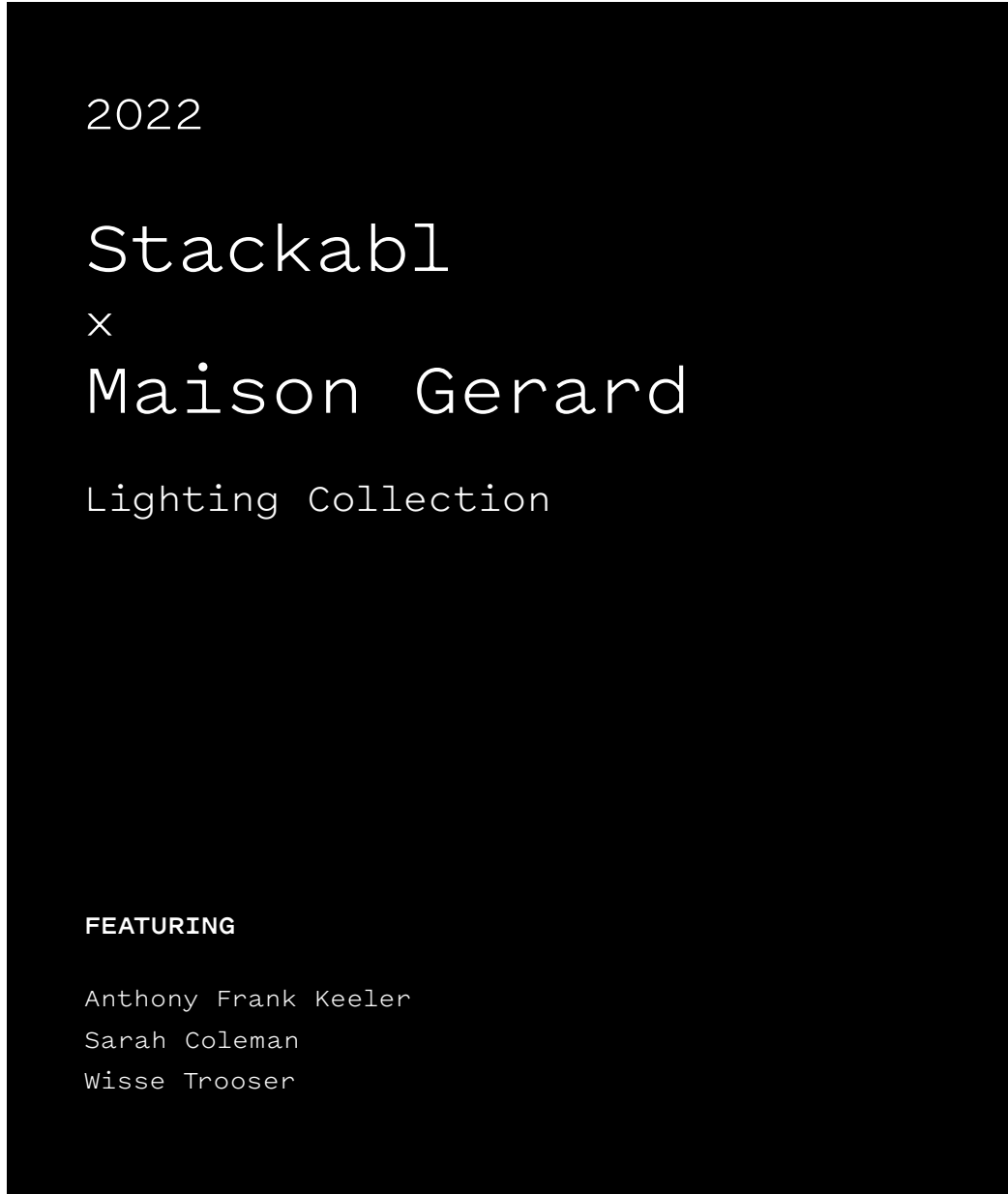

"2020," "2021," and "2022"
Feat. Sarah Coleman
Photo © Michael Mundy for Maison Gerard

2022 Stackabl x Maison Gerard - Lighting



“Hombre”
Feat. Anthony Frank Keeler
Photo © Patrick Biller for Maison Gerard



“Hombre” Long and Short
Feat. Anthony Frank Keeler
21 Mercer St., NYC | Photo © Nike For Faust

2022 Stackabl x Maison Gerard - Lighting



"2021"
Feat Sarah Coleman
Photo © Patrick Biller for Maison Gerard

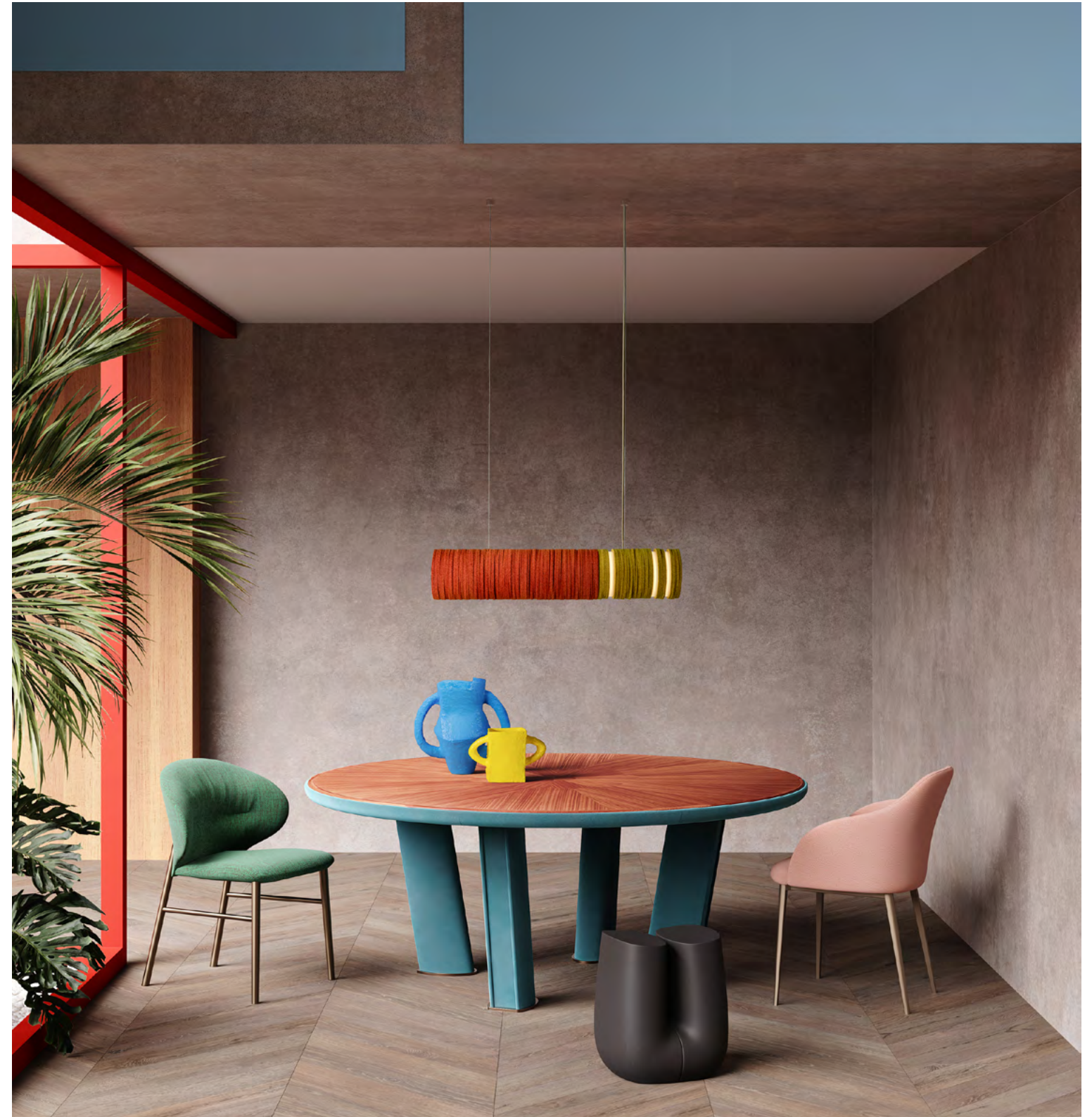

Private Residence | Milan, Italy
Visualization © Living Corriere for Studio Salaris

2022 Stackabl x Maison Gerard - Furniture



"2020," "2021," and "2022"
Feat. Sarah Coleman
Photo © Patrick Biller for Maison Gerard



Maison Gerard, New York
Photo © Michael Mundy

2022 Stackabl x Maison Gerard - Furniture

1 # 3



"Hugo, Luis, Paco"
Feat. Wisse Trooster
Photo © Patrick Biller for Maison Gerard

2023 Stackabl x Jeff Forrest

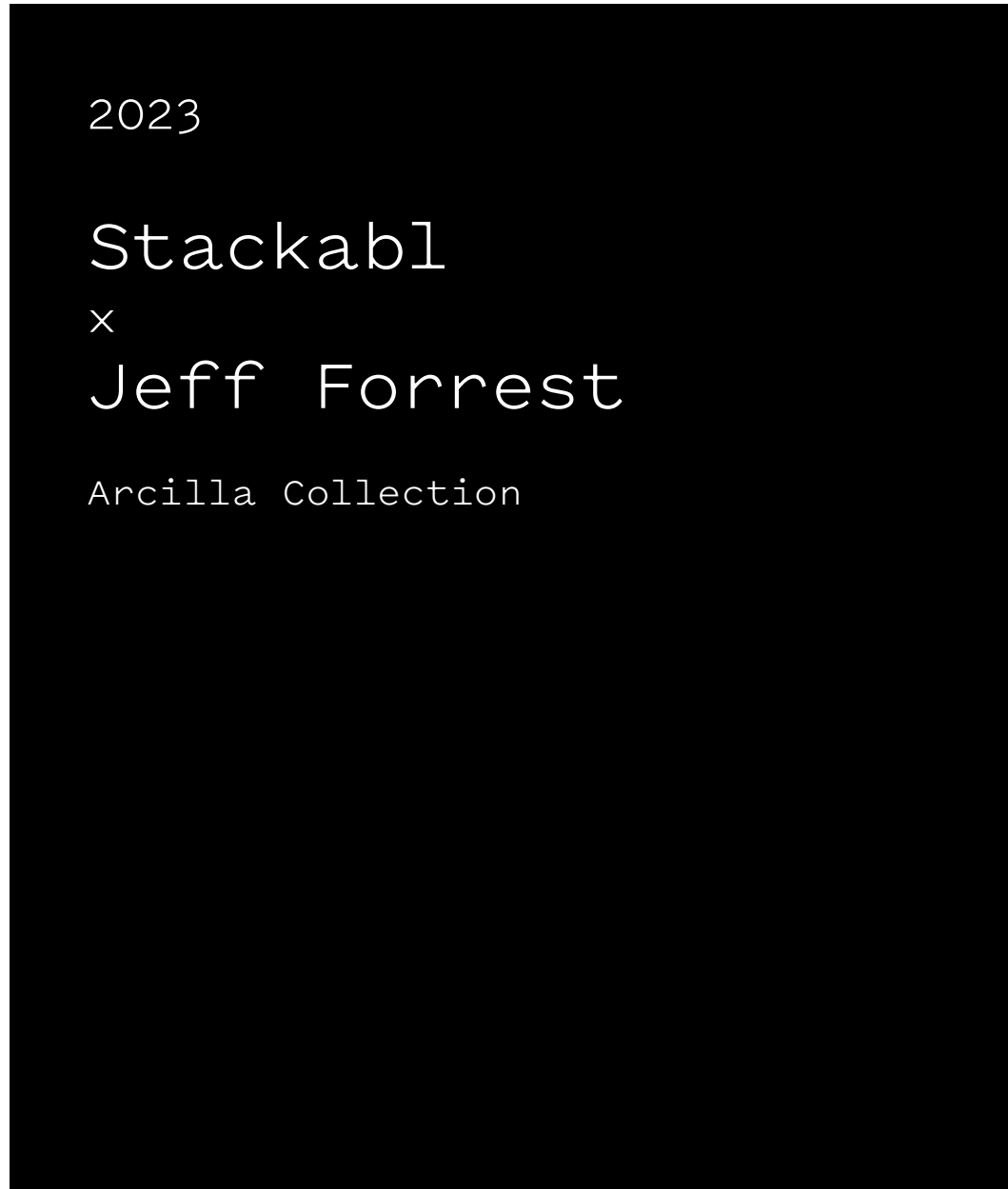

Arcilla Collection
Photo © The Lobby

--- I I ###



"Arcilla" Cluster
Feat. Jeff Forrest
Photo © Patrick Biller

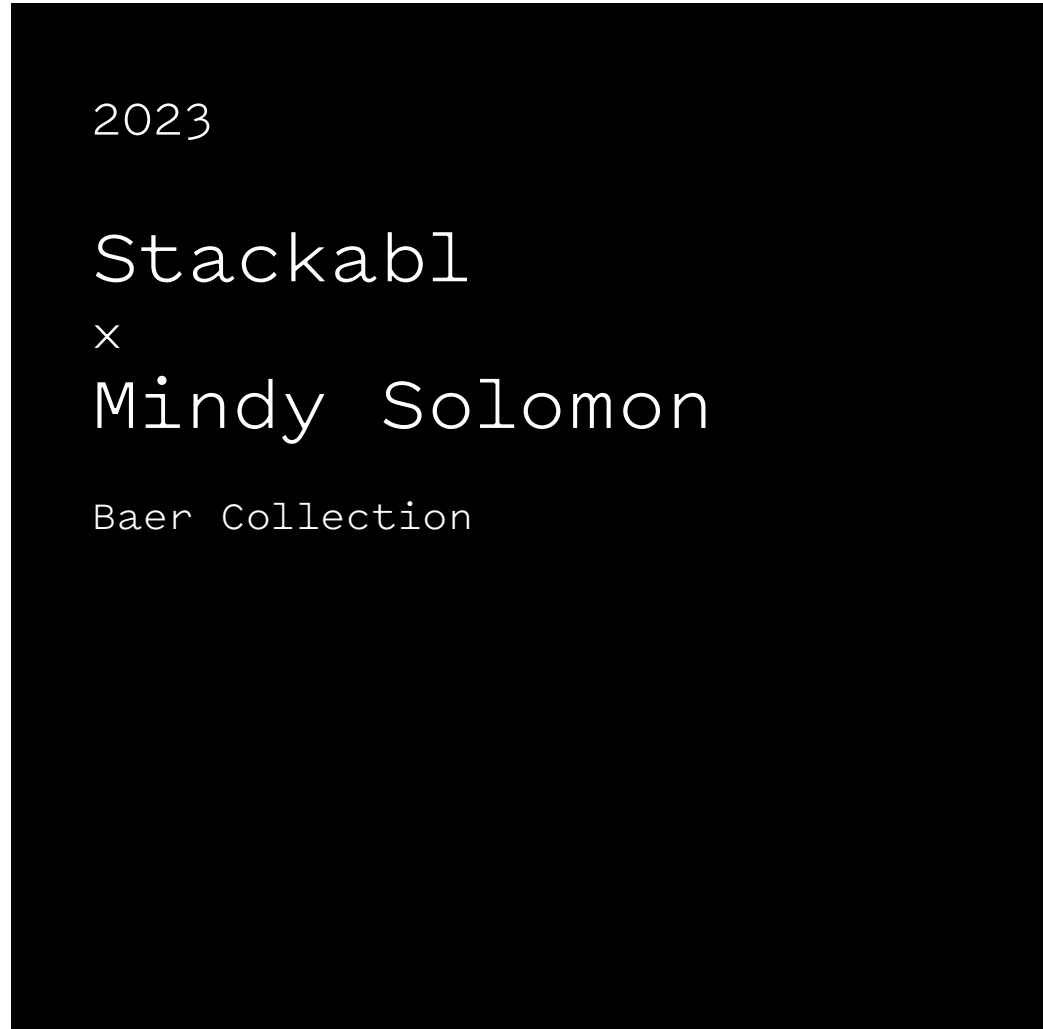

Baer Collection
Photo © James Harris for Mindy Solomon



Baer Armchair
Photo © Patrick Biller



Baer Bench
Photo © Patrick Biller



Baer Chaise
Photo © Patrick Biller

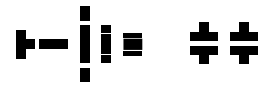

Baer Cluster
Photo © Stackabl for Mindy Solomon



Colony Cluster
Photo © Stackabl for Mindy Solomon

2024 Stackabl x Benoist F. Drut

2024
Stackabl
x
Benoist F. Drut
Night City Scape Collection



"Night City Scape" Floor Lamps, 48", 60", 86"
Photo © Patrick Biller

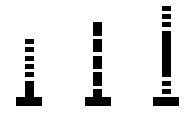

Night City Scape Floor Lamps, 48", 60", 85"
Photo © Patrick Biller



2024 Stackabl x Benoist F. Drut

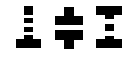

Night City Scape Pendant Cluster
Configured 08.17.24
Photo © Patrick Biller



Night City Scape 585
Configured 08.17.24
Photo © Patrick Biller

2025 Stackabl x Rockwell Group

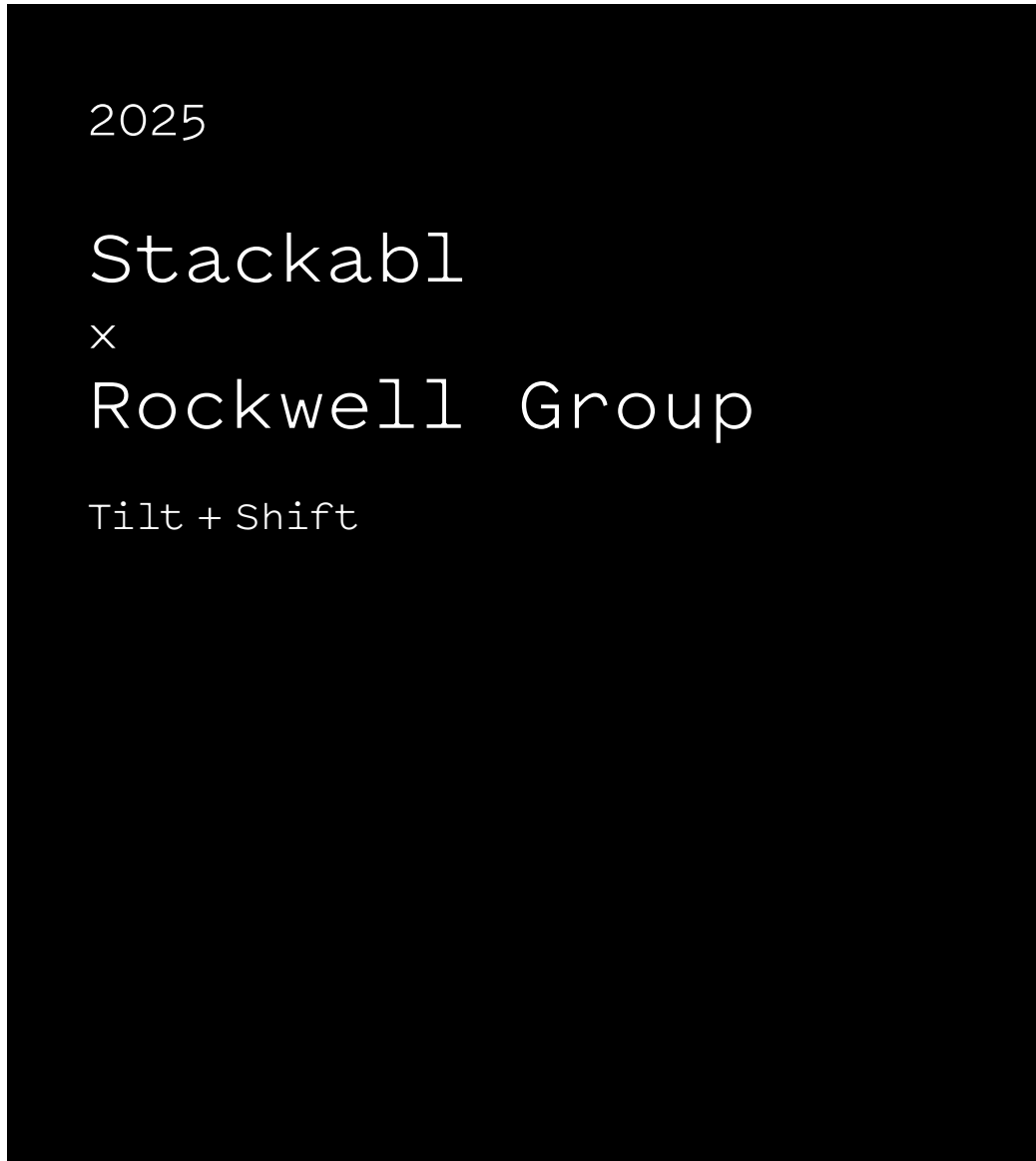

Shift 46, Tilt 06, Shift 20, Tilt 11
Photo © Patrick Biller

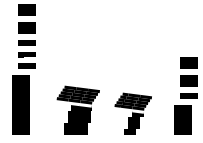

Shift 46, Tilt 11, Tilt 06, Tilt 11, Shift 20

Photo © Patrick Biller at 115 Larchmount, designed by Superkül



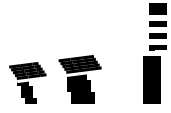

Left: Tilt 06, Tilt 11

Above: Tilt 11, Shift 36

Photo © Patrick Biller at 115 Larchmount, designed by Superkül

STACK ABL

RECOGNITION AND ENGAGEMENT

Awards, Exhibits,
Select Press,
Lectures and Panels



THIS IS A RECYCLING
SYSTEM THAT MAKES
CONFIGURABLE
FURNITURE USING
ALGORITHMS, AND
YOU CAN USE IT TOO.



AWARDS

Azure magazine
Furniture Systems and Collections AZ Awards
2022 Winner

Designlines magazine
Arcilla pendant collection DL Loves 2023 Award
Winner

Good Design
Green Good Sustainability Awards 2022 Winner

Good Design
Good Design Award 2024 for Baer Collection -
Furniture

iF Design 2026 Awards
Tilt + Shift lamp collection – Lighting

Interior Design magazine
Pendant Lighting Honoree, Best of Year Awards
2022

Interior Design magazine
Acoustical Lighting Winner, Best of Year Awards
2023

Interior Design magazine
Lighting Collection Honoree, Best of Year Awards
2025

**International Furnishings and Design
Association**
IFDA Selects Lighting Award, ICFF 2023

LIT Lighting Design Awards
Pendant Lighting Winner 2023

EXHIBITS

**Composition & Layout: Contemporary Design
And Objects via Mindy Solomon Gallery**
September 17 – October 22, 2022
Miami, Florida

Design Miami via Mindy Solomon Gallery
November 29 – December 4, 2022
Miami Beach, Florida

Design Miami via Mindy Solomon Gallery
December 5-10, 2023
Miami Beach, Florida

**Fuorisalone Milan Design Week via Isola
Design District**
June 7-12, 2022
Milan, Italy

ICFF
May 21-23, 2023
New York, New York

ICFF
May 18-20, 2025
New York, New York

Illuminate via Interior Design Show
January 22-25, 2026
Toronto, Ontario

**Kiko Lopez: Smoke and Mirrors via Maison
Gerard**
October 12 – November 15, 2022
New York, New York

Nike x Faust SB Dunk High
August 27 – September 31, 2022
New York, New York

Salon Art & Design via Maison Gerard
November 10-14, 2021
New York, New York

Salon Art & Design via Maison Gerard
November 10-14, 2022
New York, New York

Stackabl x The Lobby via DesignTO
January 2022 – March 2023
Toronto, Ontario

Stackabl x Maison Gerard
May 21 – June 30, 2023
New York, New York

Winter Show via Maison Gerard
April 1-10, 2022
New York, New York

Winter Show via Maison Gerard
January 19 - 28, 2024
New York, New York

SELECT PRESS

1stdibs
“Colorful, Customizable Stackabl Furniture is
Good for the Planet, too,” April 3, 2022

The Art Newspaper
“In pictures: Design Miami makes a stand,”
December 2023

Architectural Digest
“15 Eco-Friendly Finds We’re Loving Now,” April
2022

Archiproducts
“Reclaiming Waste and Reimagining Form,” May
2025

Aspire
“ICFF 2025: Designing in Harmony Takes Center
Stage This May,” May 2025

Azure Magazine
“Best in Show – All Show Request,” March 2022

Azure Magazine
“Stacklab Debuts a Tool to Build Fully Customized
Felt Furniture,” March 2022

Azure Magazine
“6 Major Moments We’re Looking Forward to at
Salone del Mobile 2022,” May 2022

Azure Magazine
“Milan Design Week 2022: Highlights from our
Camera Roll,” June 2022

Azure Magazine
“O, Canada! 10 Canadian Designers Making it Big
Abroad,” July 2022

Azure Magazine
“How ICFF Got Its Groove Back,” May 2023

Canadian Interiors
“STACKLAB launches a new pendant lighting
collection using upcycled felt,” September 2022

Core77
“Stackabl System Lets You Design Furniture Made
from Locally-Sourced Factory Off-Cuts,” January
2022

Core77
“Design Your Own Pendant Lighting Out of
Upcycled Felt, Using Stackabl’s Configurator,”
August 2022

CNN
“These surprising materials are the future of
furniture design,” August 2025

CURBED
“At the Salon of Art + Design, I Fell In Love With
Stackabl’s Colorful, Sustainable Furniture,”
November 2021

darc magazine
“In Focus,” November 2022

Designboom
“Stackabl Turns Manufacturing Waste into Bold
Furniture Collection at Design Miami,” December
3, 2023

Design Edit
“Benoist Drut,” May 2022

Design Milk
“Stackabl Felt Furniture Is Turning Waste Into
Wonder,” May 2022

Design Milk
“Tilt and Shift Your Eyes Towards Stackabl’s
Newest Lighting,” May 2025

Designer Pages
“Clever Felt Furniture from Stackabl,” July 2022

LECTURES & PANELS

Designers Today

“What we saw at ICFE and WantedDesign last week,” May 2023

Designers Today

“11 design trends from Miami,” April 3, 2024

DudelWantThat.com

“Stackabl Custom Recycled Furniture,” June 2023

Elle Décor

“The Family Issue,” May 2022

Elle Decoration Canada

“Radical by Design,” October 2025

Elle Decor France

“DESIGN, DECO, BOUTIQUES, EXPOS. TOUS NOS COUPS DE CŒUR (News),” January 2024

Galerie

“Creative Minds,” March 2022

Global Design News

“Jeffrey Forrest from STACKLAB and Maison Gerard turn waste into inspired furniture aiming for a more sustainable future,” July 2022

Global Design News

“Stackabl creates a furniture collection that creatively repurposes textile waste into bold, eco-friendly pieces, all inspired from the Miami Beach’s Art Deco heritage,” February, 2025

Globe and Mail

“Innovative furniture designers harness discarded fabrics for a sustainable future for home goods,” February 2022

Gray Magazine

“Configure it out,” August 2022

Homecrux

“Stackabl Brings Environmentally-Friendly Pendent Lights to Salone del Mobile,” June 2022

Homecrux

“Challenging the Conventional, Designers Explore New Materials at NYCxDesign 2025,” May 2025

House & Home

“The Healthy Home: Conscious Design Finds For Summer And Beyond,” July/August 2025

Hunker

“These 5 home design trends are about to be everywhere,” May 2023

Index Design

“Objets choisis: forme et fantaise,” September 2022

Inhabitat

“Stackabl system connects designers with manufacturing waste,” September 2022

Interior+Design

“Tilt + Shift: Cork Lights by Stackabl,” May 2025

Interior Design

“These Furnishing Debuts Nod to the Memphis Movement,” July 2022

Interior Design (Russia)

“Trends 2022/2023: recycled felt furniture,” October 2022

Interior Design

“The Spec,” June 2025

Interior Design

“Marketscape ICFE,” July/August 2025

Isola Design

“Discover how to turn waste into wonders with Stackabl,” December 2021

L’Arca International

“Design: Stackabl,” Issue 170 – 2023

LivingEtc

“7 Sustainable Product Designs That Are Setting the Agenda for Environmentally-Conscious Homes in 2025,” April 2025

Luxe Interiors + Design

“Create An Upcycled Utopia At Home With These High-End Pieces,” November 2022

Luxury Portfolio International

“Stackabl customized furnishings pack a sustainable design punch,” October 20, 2022

Mad White

“MEBLE Z ODPADÓW PRZEMYSŁOWYCH. STACKLAB UŻYŁ ZALEGAJĄCEGO FILCU,” November 2023

Metropolis

“Lighting That Lets Shape Shine,” November 5, 2025

Mexico Design

“Libertad a Colores Pendant Collection de Stackabl,” July 2023

National Post

“Home design: The best of IDS,” February 3, 2026

New York Times

“The 70th Winter Show,” January 21, 2024

Pep Up Home

“Stackabl System Creates Aesthetic Furniture with Factory Off-Cuts,” February 2022

QuePasa

“Waste with extended life and technology, Jeff Forrest’s bet,” November 30, 2022

Specialty Fabrics Review

“Fun-filled felt furniture made from factory remnants,” March 1, 2024

Stirpad

“Stacklab x Maison Gerard’s ‘Stackabl’ system enables virtual customisation of furniture,” May 2022

Stirworld

“Gabriele Cavallaro discusses the genesis and curation of Isola District District,” July 2022

Suzanne Lovell Daily

“Stackabl is both whimsical and environmentally-friendly,” May 2023

Trend Hunter

“The Stackabl Lighting Collection is Eco-Friendly,” June 2022

Trend Hunter

“Stacked Dynamic Light Collections,” May 2025

Wallpaper

“Five things we loved at ICFE this year,” May 2025

Yanko Design

“Sustainable, Beautiful and Comfy Chairs that are Made from Stacks of Factory Offcut Felt,” January 2022

Yuzu magazine

“Stackabl: Could this be a Revolution,” Winter 2022/2023

Good Future Design Alliance

Confab ‘24 | Green Design Visionaries
“The Modern Philosophy of Furniture Design,” with STACKLAB/Stackabl, Model No., and Prowl Studio
Moderated by David Charne of Fyrn
Fort Mason Center for Arts & Culture, San Francisco
September 12, 2024

Human/Nature Climate Conference

Azure Publishing
“New Materials in Product Design,” with Stackabl, Carnegie Fabrics, ekoa, and Vitra North America
Moderated by Eric Mutrie
Evergreen Brick Works, Toronto
October 29, 2025

Industrial Designers Society of America

“Design Circularity: Sustainable Futures Through Design Innovation,” with STACKLAB/Stackabl, PlsReturnIt, Lot21, and Belworld Creative Inc.
Moderated by Surya Vanka, Founder, Authentic Design, Chair-Elect, IDSA
Mingei Theatre, San Diego
September 20, 2024

SoCal Circular Textiles Summit

“Innovating for Impact,” with Stackabl, Holding Court, Tillys & Fashion Revolution USA, WSP, Impact Innovator & NSF I-Corps
ANTrepreneur Centre, UC Irvine California
May 9, 2025

STACK ABL



2026